



MN60WP
WATER
PROOF



MN60WP User Manual

About this Manual

Congratulations on purchasing the Minolta MN60WP Waterproof Camera! The contents of this manual are subject to change without notice. Note that the example screens and product illustrations shown in this User's Guide may differ somewhat from the screens and configuration of the actual camera.

Copyright

This manual contains proprietary information protected by copyright. All rights are reserved. No part of this manual may be reproduced by any mechanical, electronic or other means, in any form, without prior written permission of Elite Brands Inc. © 2023.

FEDERAL COMMUNICATIONS COMMISSION INTERFERENCE STATEMENT

This equipment has been tested and found to comply with the limits for a Class B digital device, pursuant to Part 15 of the FCC Rules. These limits are designed to provide reasonable protection against harmful interference in a residential installation. This equipment generates, uses and can radiate radio frequency energy and, if not installed and used in accordance with the instructions, may cause harmful interference to radio communications. However, there is no guarantee that interference will not occur in a particular installation. If this equipment does cause harmful interference to radio or television reception, which can be determined by turning the equipment off and on, the user is encouraged to try to correct the interference by one or more of the following measures:

- Reorient or relocate the receiving antenna.
- Increase the separation between the equipment and receiver.
- Connect the equipment into an outlet on a circuit different from that to which the receiver is connected.
- Consult the dealer or an experienced radio/TV technician for help.

CAUTION:

Any changes or modifications not expressly approved by the party responsible for compliance could void the user's authority to operate the equipment.

This device complies with Part 15 of the FCC Rules. Operation is subject to the following two conditions:

- (1) This device may not cause harmful interference and
- (2) This device must accept any interference received, including interference that may cause undesired operation.

RF Exposure Warning

This equipment complies with FCC RF radiation exposure limits set forth for an uncontrolled environment. This equipment must be installed and operated in accordance with provided instructions and must not be co-located or operating in conjunction with any other antenna or transmitter. End-users and installers must be provided with antenna installation instructions and transmitter operating

conditions for satisfying RF exposure compliance.

FCC: SAR standard Value: 1.6 W/Kg, Maximal Measure: 0.4 W/kg

CE Mark Warning

This is a Class B product, in a domestic environment, this product may cause radio interference, in which case the user may be required to take adequate measures.

Safety and Handling Precautions

Camera Information

- Do not disassemble or attempt to service the camera yourself.
- Do not expose the camera to moisture, or extreme temperatures.
- Allow the camera to warm up when moving from cold to warm temperatures.
- Do not touch and put pressure on the camera lens.
- Do not expose the lens to direct sunlight for extended periods.
- Do not use abrasive chemicals, cleaning solvents or strong detergents to clean the product. Wipe the product with a slightly damp soft cloth.
- Do not use the flash or LED Light near a person's eyes to prevent possible eye injury.
- To prevent you from falling over or resulting in traffic accident, please do not use the camera while you are walking, driving or riding a vehicle.
- Please handle the camera strap with care, and never place the strap around the neck of an infant or child. Wrapping the strap around a neck may cause suffocation.
- Do not subject the LCD screen to impact.
- To prevent the risk of fire or electric shock, do not expose the inside of this product to rain or moisture.

Battery Information

- Turn off the camera before installing or removing the battery.
- Use only the provided batteries or type of battery and charger that came with your camera. Using other types of battery or charger may damage the device and invalidate the warranty.
- Inserting the battery upside down can cause damage to the product and possibly cause an explosion.
- When the camera is used for an extended period of time, it is normal for the camera body to feel warm.
- Download all pictures and remove the battery from the camera if you are going to store the camera for a long period of time.
- Risk of explosion if battery is replaced by an incorrect type. Dispose of used

batteries according to the instructions.

- Please keep the batteries out of the reach of children to prevent from swallowing the batteries, which might cause poisoning.
- If the battery's color or shape changes in any way, stop using the battery immediately.

USB Adaptor Information

- Do not expose the adaptor to high temperatures or moisture places. Otherwise, it may cause fire or electric shock.
- Do not attempt to repair, disassemble, change or transform the adaptor.
- Avoid sudden changes in temperature, which may cause condensation on the adaptor's internal surfaces. Please do not use it immediately in this situation.
- Do not touch the plug with wet hands. Otherwise, it may cause electric shock.
- Do not use the travel voltage converter or AC/DC power inverter. Otherwise, it may cause damage, overheating, malfunction or fire to the camera.

Waterproof and Dustproof Information

- The waterproof and dustproof performance described do not guarantee that the camera will remain completely waterproof or free from damage and trouble under all conditions.
- Do not subject the camera to excessive shock, Vibration or pressure by dropping it, hitting it or placing a heavy object on it. Failure to observe this precaution could deform the camera, cause water to seep inside, or damage the airtight seals, resulting in camera malfunction.
- The battery door must be closed securely and the lock engaged in order for the camera to be waterproof. Failure to do this can allow water to enter the camera and damage it.

The camera can shoot images underwater at a depth of 3m (10ft) for up to 60 minutes.

- Do not drop the camera, strike it against a hard object such as a rock, or throw it against a water surface.
- Do not subject the camera to shock when using it underwater.
- Do not expose to depths greater than 3m (10ft) underwater.
- Do not continuously use the camera underwater for 60 minutes or more.
- Do not insert a wet memory card or battery in the camera.
- Do not open the battery cover when the camera or your hands are wet. Doing so may cause water to seep inside the camera or result in camera malfunction.
- Do not open the battery cover underwater.

1. About Your Camera

- If moisture such as water droplets adheres to the outside of the camera or inside of the battery cover, immediately wipe it off with a soft dry cloth.
- If a foreign substance adheres to the outside of the camera or inside of the battery cover, immediately remove it with a soft cloth.
- Do not leave the camera in cold conditions or hot conditions of 40°C (104°F) or more for a long period of time.
- When using the camera underwater, make sure the water temperature is from 0°C-40°C (32°F to 104°F).
- Do not use the camera in hot springs.

Before Using the Camera Underwater

Check the items below before using the camera underwater.

- Make sure that there are no foreign substances inside the battery cover.
- Make sure that the waterproof packing of the battery cover is not cracked or deformed.
- Make sure that the battery door is firmly closed and the battery cover security lock is in the LOCK position.
- Failure to follow these steps can result in damage to the camera.

Notes about Opening and Closing the Battery Door

- Make sure the camera and your hands are not wet.
- Make sure that there are no debris inside the battery-chamber or memory card slot.
- Make sure that the battery cover is firmly closed and the security lock is in the lock position.

To Unlock the Battery Door

Unlock the battery door by sliding the battery door notch away from the opening. Use a fingernail or other pointy object when sliding the latch to get a better grip.



To Lock the Battery Door

Press down on the end of the battery door where the latch is located until the battery door is completely flat and a click is heard.

Precautions When Cleaning

- Do not puncture the microphone or speaker openings with a sharp implement.
- If the inside of the camera is damaged, the waterproof performance will deteriorate.
- Do not use soap, natural detergents, or chemicals such as benzene for cleaning.

Do Not Apply Strong Impact to the Camera

The product may malfunction if subjected to strong shock or vibration. In addition, do not touch or apply force to the lens.

Avoid Sudden Changes in Temperature

Sudden changes in temperature, such as when entering or leaving a heated building on a cold day, can cause condensation to form inside the device. To prevent condensation, place the device in a carrying case or a plastic bag before exposing it to sudden changes in temperature.

Keep Away from Strong Magnetic Fields

Do not use or store this device in the vicinity of equipment that generates strong electromagnetic radiation or magnetic fields. Doing so could result in loss of data or camera malfunction.

Do Not Point the Lens at Strong Light Sources for Extended Periods

Avoid pointing the lens at the sun or other strong light source light sources for extended periods when using or storing the camera. Intense light may cause the image sensor to deteriorate or produce a white blur effect in photographs.

Turn the Product Off before Removing or Disconnecting the Power Source or Memory Card

Do not remove the battery while the product is on, or while images are being saved or deleted. Forcibly cutting power in these circumstances could result in loss of data or cause damage to the memory card or internal circuitry.

Notes about the LCD Screen

- The LCD Screens are constructed with extremely high precision; At least 99.99% of pixels are effective, with no more than 0.01% being missing or defective. Hence, while these displays may contain pixels that are always lit (white, red, blue or green) or always off (black), this is not a malfunction and has no effect on images recorded with the device.
- Images viewed on the LCD screen may be difficult to see under certain lighting.
- Do not apply pressure to the LCD screen, as this could cause damage or malfunction.

The Battery

Precautions for Use

- Note that the battery may become hot after use.
- Do not use the battery at ambient temperatures below 0°C (32°F) or above 40°C (104°F) as this could cause damage or malfunction.
- If you notice any abnormalities such as excessive heat, smoke, or an unusual smell coming from the battery, immediately discontinue use and consult your retailer.
- After removing the battery from the camera or optional battery charger, put the battery in a plastic bag, etc. in order to insulate it.

Charging the Battery

Check the battery level before using the camera and replace or charge the battery if necessary.

- Charge the battery indoors with an ambient temperature of 5°C (41°F) to 35°C (95°F) before use.
- A high battery temperature may prevent the battery from charging properly or completely, and may reduce battery performance. Note that the battery may become hot after use; wait for the battery to cool before charging. When charging the battery inserted into this camera using the Charging AC Adapter

or a computer, the battery is not charged at battery temperature below 5°C (41°F) or above 55°C (131°F).

- When the battery is between 45°C (113°F) - 55°C (131°F), the chargeable capacity may decrease.
- Do not continue charging once the battery is fully charged as this will result in reduce battery performance.
- The battery temperature may increase during charging. However, this is not a malfunction.

Using the Battery When Cold

On cold days, the capacity of batteries tends to decrease. If an exhausted battery is used at a low temperature, the camera may not turn on. Keep spare batteries in a warm place and exchange as necessary. Once warmed, a cold battery may recover some of its charge.

Recycling Used Batteries

Replace the battery when it no longer holds a charge. Used batteries are a valuable resource. Please recycle used batteries in accordance with local regulations.

Cleaning After Using the Camera Underwater

Follow the procedure below to rinse the camera with fresh water within 30 minutes after using it under saltwater or at the beach.

1. Keep the battery cover closed and wash off the camera with fresh water.
Immerse the camera in a shallow basin filled with fresh water for 10 minutes.
2. Immerse the camera in fresh water and shake it sufficiently in the water to remove any foreign substances from the camera.
3. When the camera is immersed in the water, a few air bubbles may come out from the water drain holes of the camera such as openings in the microphone or speakers. This is not a malfunction.
4. Wipe off water droplets with soft cloth and dry the camera in a well-ventilated and shady place.
5. Place the camera on a dry cloth to dry it.
6. Do not dry the camera with hot air from a hair dryer or clothes dryer.
7. After making sure that there are no water droplets on the camera, open the battery cover and use a soft dry cloth to gently wipe off any water or sand remaining on the waterproof packing or inside the camera.

If the cover is closed when the inside is wet, this could cause condensation or a malfunction.

Cleaning After Using the Camera in Conditions Other than Underwater

Use a blower to remove any dust or lint that adheres to the lens, monitor or

camera body. To remove fingerprints or other stains that cannot be removed with a blower, gently wipe the parts with a soft dry cloth. If you wipe with too much pressure or with a rough cloth, it may damage the camera or cause a malfunction.

Storage

If you do not intend to use the camera for an extended period, remove the battery and avoid storing the camera in any of the following types of locations:

- Places that are poorly ventilated or subject to humidity of over 60%
- Place exposed to temperatures above 50°C (122°F) or below -10°C (14°F).
- Place next to equipment that produces strong electromagnetic field, such as television or radios.

To prevent mold or mildew, take the camera out of storage at least once a month, and turn it on and release the shutter a few times before putting it away again.

1.1 Camera Interface



1. Shutter	10. LED Indicator
2. Switch Screen	11. Zoom In
3. Power	12. Up LED Light On/Off
4. LED Light	13. Down Delete Record Audio On/Off
5. Microphone	14. Menu
6. Speaker	15. Mode
7. Lens	16. OK Zoom Out
8. Front LCD Screen	17. Tripod Mount
9. Rear LCD Screen	18. Battery Cover/Lock

1.2 Button Function Description

Function	Description
Power	Press for 3 seconds to power on or off.
OK Zoom Out	In Settings: Tap to enter menus and confirm selected setting. In Video or Photo: Press and hold to zoom out. In Playback: Tap to play and pause recorded videos.
Zoom In	In Video or Photo: Press and hold to zoom in.
Mode	Tap to cycle between Photo, Video and Playback modes.
Menu	Tap to access the setting menus.
Up LED Light	In Video or Photo: Press to turn the LED light On and Off. In Playback: Press to go to the previous image. In Settings: Press to select desired setting.
Down Delete Record Audio	In Video or Photo: Press to turn audio recording on and off. In Playback: Press to go to the next image. Press and hold to access the delete menu for the current file. In Settings: Press to select desired setting.
Shutter	In Photo: Tap to capture a photo. In Video: Tap to start and stop recording.
Switch Screen	Switches the LCD screen that is powered on.
Tripod Mount	Mount port for attaching to a tripod nut.
Battery Door	Door to cover the battery compartment and memory card slot.
Speaker	Built-in speaker output for playback of video files when audio recording is enabled.
Lens	Front capture device for all video and photo.

1.3 To Open the Battery Door

Unlock the battery door by sliding the battery door notch away from the opening. Use a fingernail or other pointy object when sliding the latch to get a better grip. The battery door will flip up automatically when the latch is fully opened.



1.4 Installing the Battery

Insert the lithium-ion battery into the battery compartment with the metal contacts facing the inside of the camera. The battery can only be inserted one way.

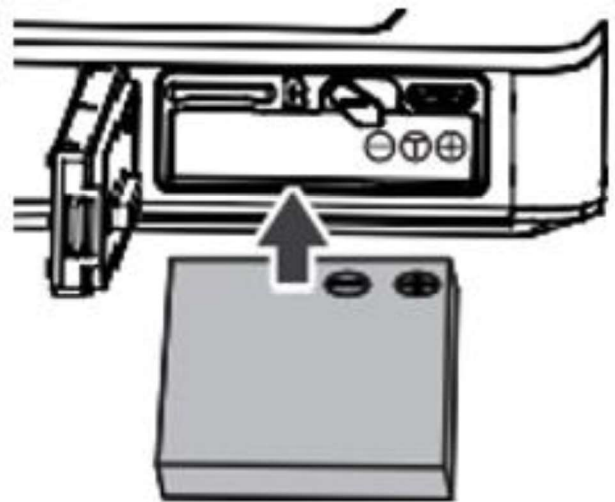
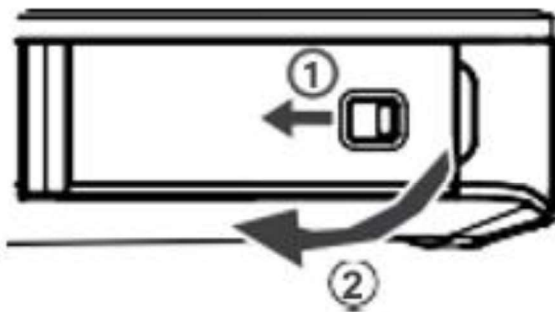

1.5 Installing the Memory Card

Insert the included MicroSD memory card to record and store your videos and photos. When the battery is low, media stored on the memory card will not be erased. Please insert the MicroSD memory card by following the steps below:

1. Open the battery door by following the diagram above.
2. Insert the memory card. Ensure that the metal contacts are inserted first.

Push the memory card down until you hear an audible click.

The memory card can only be inserted in one way. Do not force the card in if it will not go in smoothly.

3. Close the memory card door by pushing it down and a click is heard from the latch.
4. To remove the memory card, simply push in and the card will eject back out.



NOTE:

- Please format the memory card before using the camera (Caution, this will erase all data on the card).
- Do not remove or insert the memory card when recording. It may damage the card or cause data loss.
- Memory card rating must be Class 10 or above.

NOTE: After closing the battery door, make sure that the door is closed securely and the lock engaged. Failure to do this can allow water to enter the camera and cause damage.

1.6 To Lock the Battery Door

Press down on the end of the battery door where the latch is located until the battery door is completely flat and a click is heard. The battery door is fully locked once the latch clicks into place.

1.7 Charging the Battery

Connect your camera to the included AC adaptor with the USB cable provided for charging. Insert the small end of the USB plug into the camera's port under the battery door, and the larger end in to the included AC adaptor. While charging the LED indicator light will light up solid red, when finished charging the light will turn off.

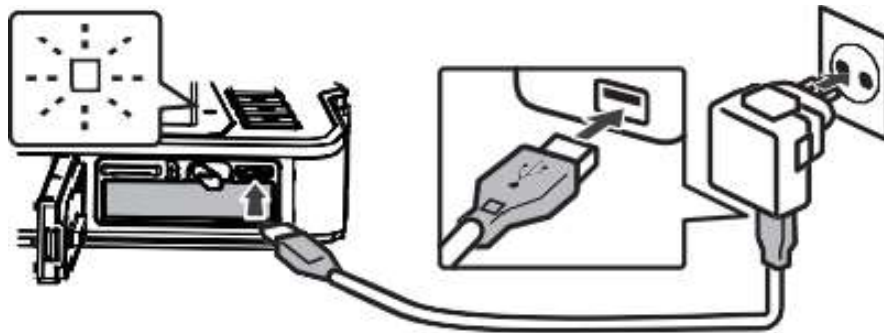

1.8 Powering the Camera On/Off

Hold the **POWER** button for 3 seconds to power the camera on. To power the camera off, press and hold the **POWER** button for a further 3 seconds. If the camera's battery is low, a "Low Power" message will display on the screen and it will automatically shut down within a few seconds to prevent memory corruption or loss.

1.9 Switching Modes

Press the **MODE** button to see the eight Photo and Video modes. Use the **UP** or **DOWN** buttons to select your desired mode, then press the **OK** button to enter that mode. The corresponding mode will be displayed in the top left corner of the screen. To enter Playback mode, press the **MODE** button to enter the mode selection screen, then press the **MODE** button again.

1.10 Connecting to a Computer

Your camera can connect to a computer to transfer photo and video files for viewing and editing, or use the camcorder as a web cam. To connect the

camcorder to your computer, open the battery door on the bottom of the camera to access the USB port. Insert the small end of the USB plug into the camcorder's port, and the larger end into the USB port on your computer. Once connected and powered on, the camcorder's screen will show three options, "Charging Mode" where the camera will function as normal while being charged, "Mass Storage Mode" where you are able to access the files on the memory card from your computer and "PC Camera" where the camera will function as a web cam. Use the **UP** or **DOWN** buttons to select your desired mode and press the **OK** button to enter into that mode.

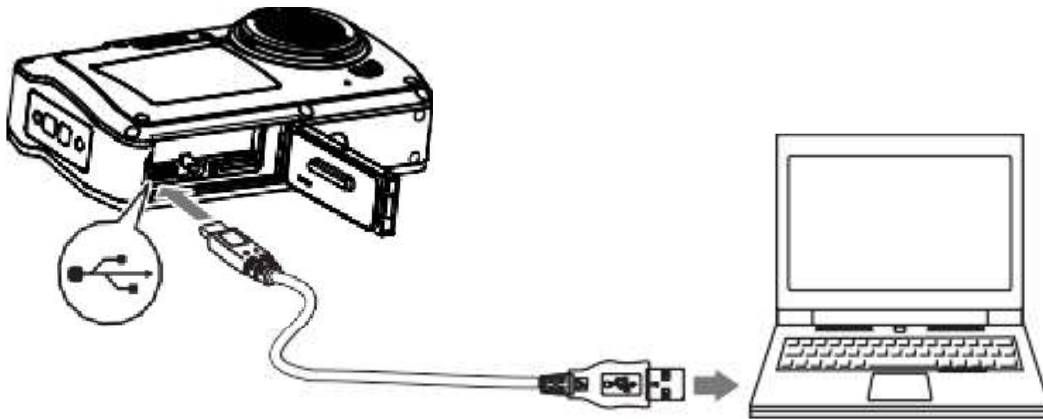

1.11 Using the Zoom Function









This camera has a digital zoom function. To operate the zoom function, press and hold the **ZOOM IN** button to zoom in closer to the subject, and press and hold the **ZOOM OUT** button zoom away from the subject.

1.12 LED Light

Your camera is equipped with an LED light that can be activated to help light dark scenes. To activate the LED light, simply press the **UP** button while in any photo or video modes. Press the **UP** button again to turn off the light.

1.13 Screen Icons

The meaning of the icons shown on the LCD screen in each mode can be found below.

Icon	Description
	Photo Mode
	Interval Photo Mode
	Burst Photo Mode
	Self-Timer Photo Mode
	Video Mode
	Slow Motion Mode
	Loop Recording Mode
	Time Lapse Mode

2. Using the Camera

2.1 Photo Shooting

To enter Photo mode, power the camera on and press the **MODE** button to access the mode selection screen and use the **UP** or **DOWN** buttons to select '*Photo*' and press the **OK** button to enter that mode.

1. Line up your shot by looking at the LCD screen to see what is in the shot.
2. Hold the camera steady and press the **SHUTTER** button to capture a photo.
3. The number of photos that can be captured at a particular resolution will be displayed in the top of the screen.
4. The number of pictures remaining will be 0 if there is no memory card inserted in the camera's memory card slot. A "Memory Full" message will be shown at the screen when the memory card is full.
5. The number of remaining photos is determined by the selected photo resolution. The higher the photo resolution, the lower the number of photos you are able to be save to the memory card. Before capturing any photos, you can select a preferred photo resolution.

The front LCD screen can be used to take selfies. Simply press the **SWITCH SCREEN** button and the front LCD screen will turn on. Then use the camera as normal. Press the **SWITCH SCREEN** button to turn the rear LCD screen back on.

Note: Only one LCD screen is active at a time, when one of the screens is off, this is not a malfunction.

2.1.1 Photo Size

This function sets the photo resolution. The higher the resolution, the greater the photo quality and the larger the file size of the photo.

1. In Photo Mode press the **MENU** button.
2. Press the **OK** button to enter the Photo mode settings.
3. Select '*Photo Size*' using the **UP** or **DOWN** buttons.
4. Press the **OK** button to enter the Photo Size submenu.
5. Press the **UP** or **DOWN** buttons to navigate the menu, and press the **OK** button to confirm your selected resolution (*48MP, 30MP, 24MP, 20MP,*

16MP, 13MP, 12MP, 8MP).

6. Press the **MENU** button twice to exit the settings menu.

2.1.2 White Balance

White Balance changes the color of light in your pictures, making it seem warmer or cooler depending on how the light you're shooting in affects the frame.

1. In Photo Mode press the **MENU** button.
2. Press the **OK** button to enter the Photo mode settings.
3. Select '*White Balance*' using the **UP** or **DOWN** buttons.
4. Press the **OK** button to enter the White Balance submenu.
5. Press the **UP** or **DOWN** buttons to navigate the menu, and press the **OK** button to confirm your selected option (*Auto, Sunny, Cloudy, Incandescent, Florescent*).
6. Press the **MENU** button twice to exit the settings menu.

2.1.3 Color Effect

This function sets the color filter effect of a photograph.

1. In Photo Mode press the **MENU** button.
2. Press the **OK** button to enter the Photo mode settings.
3. Select '*Color Effect*' using the **UP** or **DOWN** buttons.
4. Press the **OK** button to enter the Color Effect submenu.
5. Press the **UP** or **DOWN** buttons to navigate the menu, and press the **OK** button to confirm your selected option (*Normal, Black and White, Negative, Retro, Red, Green, Blue*).
6. Press the **MENU** button twice to exit the settings menu.

2.1.4 Exposure

This function adjusts the frame brightness in your photograph.

1. In Photo Mode press the **MENU** button.
2. Press the **OK** button to enter the Photo mode settings.
3. Select '*Exposure*' using the **UP** or **DOWN** buttons.
4. Press the **OK** button to enter the Exposure submenu.
5. Press the **UP** or **DOWN** buttons to navigate the menu, and press the **OK** button to confirm your selected option (*-3, -2, -1, 0, +1, +2, +3*).

6. Press the **MENU** button twice to exit the settings menu.

2.1.5 Metering

Metering mode refers to the way in which a camera determines the appropriate exposure (quantity of light reaching the camera lens). Spot metering will only base the exposure setting on a very small area of the scene. Center metering will use the light from the center of the LCD and the Multi setting measures the light at several points on the screen.

1. In Photo Mode press the **MENU** button.
2. Press the **OK** button to enter the Photo mode settings.
3. Select '*Metering*' using the **UP** or **DOWN** buttons.
4. Press the **OK** button to enter the Metering submenu.
5. Press the **UP** or **DOWN** buttons to navigate the menu, and press the **OK** button to confirm your selected option (*Multi, Center, Spot, Matrix*).
6. Press the **MENU** button twice to exit the settings menu.

2.1.6 Image Sharpness

This function adjusts the visible detail of a photograph.

1. In Photo Mode press the **MENU** button.
2. Press the **OK** button to enter the Photo mode settings.
3. Select '*Sharpness*' using the **UP** or **DOWN** buttons.
4. Press the **OK** button to enter the Sharpness submenu.
5. Press the **UP** or **DOWN** buttons to navigate the menu, and press the **OK** button to confirm your selected option (*Sharp, Normal, Soft*).
6. Press the **MENU** button twice to exit the settings menu.

2.1.7 Long Exposure

This function allows you to set the amount of time that the camera's shutter is left open. The resulting image captures the trail of moving objects in front of the camera, while showing still elements razor sharp.

1. In Photo Mode press the **MENU** button.
2. Press the **OK** button to enter the Photo mode settings.
3. Select '*Long Exposure*' using the **UP** or **DOWN** buttons.
4. Press the **OK** button to enter the Long Exposure submenu.
5. Press the **UP** or **DOWN** buttons to navigate the menu, and press the **OK**

button to confirm your selected option (*Auto, 2 Seconds, 5 Seconds, 10 Seconds, 15 Seconds, 20 Seconds, 30 Seconds*).

6. Press the **MENU** button twice to exit the settings menu.

2.1.8 ISO

This function adjusts the light sensitivity in your photograph.

1. In Photo Mode press the **MENU** button.
2. Press the **OK** button to enter the Photo mode settings.
3. Select '*ISO*' using the **UP** or **DOWN** buttons.
4. Press the **OK** button to enter the ISO submenu.
5. Press the **UP** or **DOWN** buttons to navigate the menu, and press the **OK** button to confirm your selected option (*Auto, 100, 200, 400, 800, 1600, 3200, 6400*).
6. Press the **MENU** button twice to exit the settings menu.

2.1.9 Time Stamp

This setting allows you to imprint a date & time onto your captured image files. Once an image file is captured with the imprint, the imprint cannot be removed.

1. In Photo Mode press the **MENU** button.
2. Press the **OK** button to enter the Photo mode settings.
3. Select '*Time Stamp*' using the **UP** or **DOWN** buttons.
4. Press the **OK** button to turn Time Stamp on and off, a check mark indicates that the feature is active.
5. Press the **MENU** button twice to exit the settings menu.

2.1.10 Field of View

This function lets you set the field of view that the camera captures.

1. In Photo Mode press the **MENU** button.
2. Press the **OK** button to enter the Photo mode settings.
3. Select '*Field of View*' using the **UP** or **DOWN** buttons.
4. Press the **OK** button to enter the Field of View submenu.
5. Press the **UP** or **DOWN** buttons to navigate the menu, and press the **OK** button to confirm your selected option (*Wide, Standard, Narrow*).
6. Press the **MENU** button twice to exit the settings menu.

2.2 Interval Photo

In the interval photo mode, the camera will take a single photo at a set time interval until stopped.

To enter Interval Photo mode, power the camera on and press the **MODE** button to access the mode selection screen and use the **UP** or **DOWN** buttons to select '*Interval*' and press the **OK** button to enter that mode.

1. Line up your shot by looking at the LCD screen to see what is in the shot.
2. Hold the camera steady and press the **SHUTTER** button to capture a photo and start the countdown.
3. At the end of each countdown, a new photo will be captured, each captured photo will be saved as an individual file.
4. To end the interval photo, press the **SHUTTER** button.
5. The number of photos that can be captured at a particular resolution will be displayed at the top of the screen.
6. The number of pictures remaining will be 0 if there is no memory card inserted in the camera's memory card slot. A "Memory Full" message will be shown on the screen when the memory card is full.
7. The number of remaining photos is determined by the selected photo resolution. The higher the photo resolution, the lower the number of photos you are able to be save to the memory card. Before capturing any photos, you can select a preferred photo resolution.

The front LCD screen can be used to take selfies. Simply press the **SWITCH SCREEN** button and the front LCD screen will turn on. Then use the camera as normal. Press the **SWITCH SCREEN** button to turn the rear LCD screen back on.

Note: Only one LCD screen is active at a time, when one of the screens is off, this is not a malfunction.

2.2.1 Photo Size

This function sets the photo resolution. The higher the resolution, the greater the photo quality and the larger the file size of the photo.

1. In Interval Photo Mode press the **MENU** button.

2. Press the **OK** button to enter the Photo mode settings.
3. Select '*Photo Size*' using the **UP** or **DOWN** buttons.
4. Press the **OK** button to enter the Photo Size submenu.
5. Press the **UP** or **DOWN** buttons to navigate the menu, and press the **OK** button to confirm your selected resolution (*48MP, 30MP, 24MP, 20MP, 16MP, 13MP, 12MP, 8MP*).
6. Press the **MENU** button twice to exit the settings menu.

2.2.2 Interval Duration

This function will let you set the amount of time between each photo.

1. In Interval Photo Mode press the **MENU** button.
2. Press the **OK** button to enter the Photo mode settings.
3. Select '*Interval Duration*' using the **UP** or **DOWN** buttons.
4. Press the **OK** button to enter the Interval Duration submenu.
5. Press the **UP** or **DOWN** buttons to navigate the menu, and press the **OK** button to confirm your selected resolution (*3 Seconds, 10 Seconds, 15 Seconds, 20 Seconds, 30 Seconds*).
6. Press the **MENU** button twice to exit the settings menu

2.2.3 Color Effect

This function sets the color filter effect of a photograph.

1. In Interval Photo Mode press the **MENU** button.
2. Press the **OK** button to enter the Photo mode settings.
3. Select '*Color Effect*' using the **UP** or **DOWN** buttons.
4. Press the **OK** button to enter the Color Effect submenu.
5. Press the **UP** or **DOWN** buttons to navigate the menu, and press the **OK** button to confirm your selected option (*Normal, Black and White, Negative, Retro, Red, Green, Blue*).
6. Press the **MENU** button twice to exit the settings menu.

2.2.4 White Balance

White Balance changes the color of light in your pictures, making it seem warmer or cooler depending on how the light you're shooting in affects the frame.

1. In Interval Photo Mode press the **MENU** button.

2. Press the **OK** button to enter the Photo mode settings.
3. Select '*White Balance*' using the **UP** or **DOWN** buttons.
4. Press the **OK** button to enter the White Balance submenu.
5. Press the **UP** or **DOWN** buttons to navigate the menu, and press the **OK** button to confirm your selected option (*Auto, Sunny, Cloudy, Incandescent, Florescent*).
6. Press the **MENU** button twice to exit the settings menu.

2.2.5 Exposure

This function adjusts the frame brightness in your photograph.

1. In Interval Photo Mode press the **MENU** button.
2. Press the **OK** button to enter the Photo mode settings.
3. Select '*Exposure*' using the **UP** or **DOWN** buttons.
4. Press the **OK** button to enter the Exposure submenu.
5. Press the **UP** or **DOWN** buttons to navigate the menu, and press the **OK** button to confirm your selected option (*-3, -2, -1, 0, +1, +2, +3*).
6. Press the **MENU** button twice to exit the settings menu.

2.2.6 Metering

Metering mode refers to the way in which a camera determines the appropriate exposure (quantity of light reaching the camera lens). Spot metering will only base the exposure setting on a very small area of the scene. Center metering will use the light from the center of the LCD and the Multi setting measures the light at several points on the screen.

1. In Interval Photo Mode press the **MENU** button.
2. Press the **OK** button to enter the Photo mode settings.
3. Select '*Metering*' using the **UP** or **DOWN** buttons.
4. Press the **OK** button to enter the Metering submenu.
5. Press the **UP** or **DOWN** buttons to navigate the menu, and press the **OK** button to confirm your selected option (*Multi, Center, Spot, Matrix*).
6. Press the **MENU** button twice to exit the settings menu.

2.2.7 Image Sharpness

This function adjusts the visible detail of a photograph.

1. In Interval Photo Mode press the **MENU** button.

2. Press the **OK** button to enter the Photo mode settings.
3. Select '*Sharpness*' using the **UP** or **DOWN** buttons.
4. Press the **OK** button to enter the Sharpness submenu.
5. Press the **UP** or **DOWN** buttons to navigate the menu, and press the **OK** button to confirm your selected option (*Sharp, Normal, Soft*).
6. Press the **MENU** button twice to exit the settings menu.

2.2.8 ISO

This function adjusts the light sensitivity in your photograph.

1. In Interval Photo Mode press the **MENU** button.
2. Press the **OK** button to enter the Photo mode settings.
3. Select '*ISO*' using the **UP** or **DOWN** buttons.
4. Press the **OK** button to enter the ISO submenu.
5. Press the **UP** or **DOWN** buttons to navigate the menu, and press the **OK** button to confirm your selected option (*Auto, 100, 200, 400, 800, 1600, 3200, 6400*).
6. Press the **MENU** button twice to exit the settings menu.

2.2.9 Time Stamp

This setting allows you to imprint a date & time onto your captured image files. Once an image file is captured with the imprint, the imprint cannot be removed.

1. In Interval Photo Mode press the **MENU** button.
2. Press the **OK** button to enter the Photo mode settings.
3. Select '*Time Stamp*' using the **UP** or **DOWN** buttons.
4. Press the **OK** button to turn Time Stamp on and off, a check mark indicates that the feature is active.
5. Press the **MENU** button twice to exit the settings menu.

2.2.10 Field of View

This function lets you set the field of view that the camera captures.

1. In Interval Photo Mode press the **MENU** button.
2. Press the **OK** button to enter the Photo mode settings.
3. Select '*Field of View*' using the **UP** or **DOWN** buttons.
4. Press the **OK** button to enter the Field of View submenu.

5. Press the **UP** or **DOWN** buttons to navigate the menu, and press the **OK** button to confirm your selected option (*Wide, Standard, Narrow*).
6. Press the **MENU** button twice to exit the settings menu.

2.3 Photo Burst

In photo burst mode, the camera will take a set number of images with each press of the **SHUTTER** button.

To enter Photo Burst mode, power the camera on and press the **MODE** button to access the mode selection screen and use the **UP** or **DOWN** buttons to select '*Burst*' and press the **OK** button to enter that mode.

1. Line up your shot by looking at the LCD screen to see what is in the shot.
2. Hold the camera steady and press the **SHUTTER** button to capture a photo.
3. The number of photos that can be captured at a particular resolution will be displayed in the top of the screen.
4. The number of pictures remaining will be 0 if there is no memory card inserted in the camera's memory card slot. A "Memory Full" message will be shown at the screen when the memory card is full.
5. The number of remaining photos is determined by the selected photo resolution. The higher the photo resolution, the lower the number of photos you are able to be save to the memory card. Before capturing any photos, you can select a preferred photo resolution.

The front LCD screen can be used to take selfies. Simply press the **SWITCH SCREEN** button and the front LCD screen will turn on. Then use the camera as normal. Press the **SWITCH SCREEN** button to turn the rear LCD screen back on.

Note: Only one LCD screen is active at a time, when one of the screens is off, this is not a malfunction.

2.3.1 Photo Size

This function sets the photo resolution. The higher the resolution, the greater the photo quality and the larger the file size of the photo.

1. In Photo Burst Mode press the **MENU** button.
2. Press the **OK** button to enter the Photo mode settings.
3. Select '*Photo Size*' using the **UP** or **DOWN** buttons.
4. Press the **OK** button to enter the Photo Size submenu.

5. Press the **UP** or **DOWN** buttons to navigate the menu, and press the **OK** button to confirm your selected resolution (*48MP, 30MP, 24MP, 20MP, 16MP, 13MP, 12MP, 8MP*).
6. Press the **MENU** button twice to exit the settings menu.

2.3.2 Photo Burst

This function lets you set the number of photos captured with each photo burst.

1. In Photo Burst Mode press the **MENU** button.
2. Press the **OK** button to enter the Photo mode settings.
3. Select '*Photo Burst*' using the **UP** or **DOWN** buttons.
4. Press the **OK** button to enter the Photo Burst submenu.
5. Press the **UP** or **DOWN** buttons to navigate the menu, and press the **OK** button to confirm your selected resolution (*3-Photo Burst, 5-Photo Burst, 10-Photo Burst*).
6. Press the **MENU** button twice to exit the settings menu

2.3.3 Color Effect

This function sets the color filter effect of a photograph.

1. In Photo Burst Mode press the **MENU** button.
2. Press the **OK** button to enter the Photo mode settings.
3. Select '*Color Effect*' using the **UP** or **DOWN** buttons.
4. Press the **OK** button to enter the Color Effect submenu.
5. Press the **UP** or **DOWN** buttons to navigate the menu, and press the **OK** button to confirm your selected option (*Normal, Black and White, Negative, Retro, Red, Green, Blue*).
6. Press the **MENU** button twice to exit the settings menu.

2.3.4 White Balance

White Balance changes the color of light in your pictures, making it seem warmer or cooler depending on how the light you're shooting in affects the frame.

1. In Photo Burst Mode press the **MENU** button.
2. Press the **OK** button to enter the Photo mode settings.
3. Select '*White Balance*' using the **UP** or **DOWN** buttons.
4. Press the **OK** button to enter the White Balance submenu.

5. Press the **UP** or **DOWN** buttons to navigate the menu, and press the **OK** button to confirm your selected option (*Auto, Sunny, Cloudy, Incandescent, Florescent*).
6. Press the **MENU** button twice to exit the settings menu.

2.3.5 Exposure

This function adjusts the frame brightness in your photograph.

1. In Photo Burst Mode press the **MENU** button.
2. Press the **OK** button to enter the Photo mode settings.
3. Select '*Exposure*' using the **UP** or **DOWN** buttons.
4. Press the **OK** button to enter the Exposure submenu.
5. Press the **UP** or **DOWN** buttons to navigate the menu, and press the **OK** button to confirm your selected option (*-3, -2, -1, 0, +1, +2, +3*).
6. Press the **MENU** button twice to exit the settings menu.

2.3.6 Metering

Metering mode refers to the way in which a camera determines the appropriate exposure (quantity of light reaching the camera lens). Spot metering will only base the exposure setting on a very small area of the scene. Center metering will use the light from the center of the LCD and the Multi setting measures the light at several points on the screen.

1. In Photo Burst Mode press the **MENU** button.
2. Press the **OK** button to enter the Photo mode settings.
3. Select '*Metering*' using the **UP** or **DOWN** buttons.
4. Press the **OK** button to enter the Metering submenu.
5. Press the **UP** or **DOWN** buttons to navigate the menu, and press the **OK** button to confirm your selected option (*Multi, Center, Spot, Matrix*).
6. Press the **MENU** button twice to exit the settings menu.

2.3.7 Image Sharpness

This function adjusts the visible detail of a photograph.

1. In Photo Burst Mode press the **MENU** button.
2. Press the **OK** button to enter the Photo mode settings.
3. Select '*Sharpness*' using the **UP** or **DOWN** buttons.
4. Press the **OK** button to enter the Sharpness submenu.

5. Press the **UP** or **DOWN** buttons to navigate the menu, and press the **OK** button to confirm your selected option (*Sharp, Normal, Soft*).
6. Press the **MENU** button twice to exit the settings menu.

2.3.8 ISO

This function adjusts the light sensitivity in your photograph.

1. In Photo Burst Mode press the **MENU** button.
2. Press the **OK** button to enter the Photo mode settings.
3. Select '*ISO*' using the **UP** or **DOWN** buttons.
4. Press the **OK** button to enter the ISO submenu.
5. Press the **UP** or **DOWN** buttons to navigate the menu, and press the **OK** button to confirm your selected option (*Auto, 100, 200, 400, 800, 1600, 3200, 6400*).
6. Press the **MENU** button twice to exit the settings menu.

2.3.9 Time Stamp

This setting allows you to imprint a date & time onto your captured image files. Once an image file is captured with the imprint, the imprint cannot be removed.

1. In Photo Burst Mode press the **MENU** button.
2. Press the **OK** button to enter the Photo mode settings.
3. Select '*Time Stamp*' using the **UP** or **DOWN** buttons.
4. Press the **OK** button to turn Time Stamp on and off, a check mark indicates that the feature is active.
5. Press the **MENU** button twice to exit the settings menu.

2.3.10 Field of View

This function lets you set the field of view that the camera captures.

1. In Photo Burst Mode press the **MENU** button.
2. Press the **OK** button to enter the Photo mode settings.
3. Select '*Field of View*' using the **UP** or **DOWN** buttons.
4. Press the **OK** button to enter the Field of View submenu.
5. Press the **UP** or **DOWN** buttons to navigate the menu, and press the **OK** button to confirm your selected option (*Wide, Standard, Narrow*).
6. Press the **MENU** button twice to exit the settings menu.

2.4 Self-Timer

In Self Timer mode, the camera will take a single picture after a set amount of time has elapsed with each press of the **SHUTTER** button.

To enter Self Timer mode, power the camera on and press the **MODE** button to access the mode selection screen and use the **UP** or **DOWN** buttons to select '*Timer*' and press the **OK** button to enter that mode.

1. Line up your shot by looking at the LCD screen to see what is in the shot.
2. Hold the camera steady and press the **SHUTTER** button to start a countdown, when the countdown ends, a picture is captured.
3. The number of photos that can be captured at a particular resolution will be displayed at the top of the screen.
4. The number of pictures remaining will be 0 if there is no memory card inserted in the camera's memory card slot. A "Memory Full" message will be shown on the screen when the memory card is full.
5. The number of remaining photos is determined by the selected photo resolution. The higher the photo resolution, the lower the number of photos you are able to be save to the memory card. Before capturing any photos, you can select a preferred photo resolution.

2.4.1 Photo Size

This function sets the photo resolution. The higher the resolution, the greater the photo quality and the larger the file size of the photo.

1. In Self-Timer Mode press the **MENU** button.
2. Press the **OK** button to enter the Photo mode settings.
3. Select '*Photo Size*' using the **UP** or **DOWN** buttons.
4. Press the **OK** button to enter the Photo Size submenu.
5. Press the **UP** or **DOWN** buttons to navigate the menu, and press the **OK** button to confirm your selected resolution (*48MP, 30MP, 24MP, 20MP, 16MP, 13MP, 12MP, 8MP*).
6. Press the **MENU** button twice to exit the settings menu.

2.4.2 Self-Timer

This function determines the time delay before a photograph is captured. This setting can be used by photographers to take photographs of themselves.

2. Using Your Camera

1. In Self-Timer Mode press the **MENU** button.
2. Press the **OK** button to enter the Photo mode settings.
3. Select '*Self-Timer*' using the **UP** or **DOWN** buttons.
4. Press the **OK** button to enter the Self-Timer submenu.
5. Press the **UP** or **DOWN** buttons to navigate the menu, and press the **OK** button to confirm your selected resolution (*3 Seconds, 5 Seconds, 10 Seconds, 20 Seconds*).
6. Press the **MENU** button twice to exit the settings menu

2.4.3 White Balance

White Balance changes the color of light in your pictures, making it seem warmer or cooler depending on how the light you're shooting in affects the frame.

1. In Self-Timer Mode press the **MENU** button.
2. Press the **OK** button to enter the Photo mode settings.
3. Select '*White Balance*' using the **UP** or **DOWN** buttons.
4. Press the **OK** button to enter the White Balance submenu.
5. Press the **UP** or **DOWN** buttons to navigate the menu, and press the **OK** button to confirm your selected option (*Auto, Sunny, Cloudy, Incandescent, Florescent*).
6. Press the **MENU** button twice to exit the settings menu.

2.4.4 Color Effect

This function sets the color filter effect of a photograph.

1. In Self-Timer Mode press the **MENU** button.
2. Press the **OK** button to enter the Photo mode settings.
3. Select '*Color Effect*' using the **UP** or **DOWN** buttons.
4. Press the **OK** button to enter the Color Effect submenu.
5. Press the **UP** or **DOWN** buttons to navigate the menu, and press the **OK** button to confirm your selected option (*Normal, Black and White, Negative, Retro, Red, Green, Blue*).
6. Press the **MENU** button twice to exit the settings menu.

2.4.5 Exposure

This function adjusts the frame brightness in your photograph.

1. In Self-Timer Mode press the **MENU** button.
2. Press the **OK** button to enter the Photo mode settings.
3. Select '*Exposure*' using the **UP** or **DOWN** buttons.
4. Press the **OK** button to enter the Exposure submenu.
5. Press the **UP** or **DOWN** buttons to navigate the menu, and press the **OK** button to confirm your selected option (-3, -2, -1, 0, +1, +2, +3).
6. Press the **MENU** button twice to exit the settings menu.

2.4.6 Metering

Metering mode refers to the way in which a camera determines the appropriate exposure (quantity of light reaching the camera lens). Spot metering will only base the exposure setting on a very small area of the scene. Center metering will use the light from the center of the LCD and the Multi setting measures the light at several points on the screen.

1. In Self-Timer Mode press the **MENU** button.
2. Press the **OK** button to enter the Photo mode settings.
3. Select '*Metering*' using the **UP** or **DOWN** buttons.
4. Press the **OK** button to enter the Metering submenu.
5. Press the **UP** or **DOWN** buttons to navigate the menu, and press the **OK** button to confirm your selected option (*Multi, Center, Spot, Matrix*).
6. Press the **MENU** button twice to exit the settings menu.

2.4.7 Image Sharpness

This function adjusts the visible detail of a photograph.

1. In Self-Timer Mode press the **MENU** button.
2. Press the **OK** button to enter the Photo mode settings.
3. Select '*Sharpness*' using the **UP** or **DOWN** buttons.
4. Press the **OK** button to enter the Sharpness submenu.
5. Press the **UP** or **DOWN** buttons to navigate the menu, and press the **OK** button to confirm your selected option (*Sharp, Normal, Soft*).
6. Press the **MENU** button twice to exit the settings menu.

2.4.8 ISO

This function adjusts the light sensitivity in your photograph.

1. In Self-Timer Mode press the **MENU** button.

2. Press the **OK** button to enter the Photo mode settings.
3. Select '*ISO*' using the **UP** or **DOWN** buttons.
4. Press the **OK** button to enter the ISO submenu.
5. Press the **UP** or **DOWN** buttons to navigate the menu, and press the **OK** button to confirm your selected option (*Auto, 100, 200, 400, 800, 1600, 3200, 6400*).
6. Press the **MENU** button twice to exit the settings menu.

2.4.9 Time Stamp

This setting allows you to imprint a date & time onto your captured image files. Once an image file is captured with the imprint, the imprint cannot be removed.

1. In Self-Timer Mode press the **MENU** button.
2. Press the **OK** button to enter the Photo mode settings.
3. Select '*Time Stamp*' using the **UP** or **DOWN** buttons.
4. Press the **OK** button to turn Time Stamp on and off, a check mark indicates that the feature is active.
5. Press the **MENU** button twice to exit the settings menu.

2.4.10 Field of View

This function lets you set the field of view that the camera captures.

1. In Self-Timer Mode press the **MENU** button.
2. Press the **OK** button to enter the Photo mode settings.
3. Select '*Field of View*' using the **UP** or **DOWN** buttons.
4. Press the **OK** button to enter the Field of View submenu.
5. Press the **UP** or **DOWN** buttons to navigate the menu, and press the **OK** button to confirm your selected option (*Wide, Standard, Narrow*).
6. Press the **MENU** button twice to exit the settings menu.

2.5 Video Recording

Power the camera on and the camera will be ready to record videos right away.

1. Line up your shot by looking at the LCD screen to see what is in view.
2. Hold the camera steady and press the **SHUTTER** button to begin recording.
3. When recording begins, a rolling timer will display in red in the top left corner of the screen. This indicates the recorded video time elapsed.
4. Press the **SHUTTER** button to stop recording.
5. The recorded video files will automatically save onto the inserted memory card.

The front LCD screen can be used to take selfies. Simply press the **SWITCH SCREEN** button and the front LCD screen will turn on. Then use the camera as normal. Press the **SWITCH SCREEN** button to turn the rear LCD screen back on.

Note: Only one LCD screen is active at a time, when one of the screens is off, this is not a malfunction

2.5.1 Movie Size

Your camera has a number of preset resolutions and frames per second rates.

1. In Video Mode press the **MENU** button.
2. Press the **OK** button to enter the Photo mode settings.
3. Select '*Movie Size*' using the **UP** or **DOWN** buttons.
4. Press the **OK** button to enter the Movie Size submenu.
5. Press the **UP** or **DOWN** buttons to navigate the menu, and press the **OK** button to confirm your selected resolution (*4K (30fps), 2.7K (30fps), 1080P (120fps), 1080P (60fps), 1080P (30fps), 720P (240fps), 720P (120fps), 720P (60fps), 720P (30fps)*).
6. Press the **MENU** button twice to exit the settings menu.

2.5.2 Image Stabilization

This function enables photo capture in high speed and low-light by

electronically minimizing motion blur and reducing camera shake.

1. In Video Mode press the **MENU** button.
2. Press the **OK** button to enter the Photo mode settings.
3. Select '*Image Stabilization*' using the **UP** or **DOWN** buttons.
4. Press the **OK** button to turn Image Stabilization on and off, a check mark indicates that the feature is active.
5. Press the **MENU** button twice to exit the settings menu.

Note: Image Stabilization and Distortion correction cannot be active at the same time.

2.5.3 Distortion Correction

This function enables the camera to correct slight image distortions by straightening the image.

1. In Video Mode press the **MENU** button.
2. Press the **OK** button to enter the Photo mode settings.
3. Select '*Distortion Correction*' using the **UP** or **DOWN** buttons.
4. Press the **OK** button to turn Distortion Correction on and off, a check mark indicates that the feature is active.
5. Press the **MENU** button twice to exit the settings menu.

2.5.4 White Balance

White Balance changes the color of light in your pictures, making it seem warmer or cooler depending on how the light you're shooting in affects the frame.

1. In Video Mode press the **MENU** button.
2. Press the **OK** button to enter the Photo mode settings.
3. Select '*White Balance*' using the **UP** or **DOWN** buttons.
4. Press the **OK** button to enter the White Balance submenu.
5. Press the **UP** or **DOWN** buttons to navigate the menu, and press the **OK** button to confirm your selected option (*Auto, Sunny, Cloudy, Incandescent, Florescent*).
6. Press the **MENU** button twice to exit the settings menu.

2.5.5 Exposure

This function adjusts the frame brightness in your photograph.

1. In Video Mode press the **MENU** button.
2. Press the **OK** button to enter the Photo mode settings.
3. Select '*Exposure*' using the **UP** or **DOWN** buttons.
4. Press the **OK** button to enter the Exposure submenu.
5. Press the **UP** or **DOWN** buttons to navigate the menu, and press the **OK** button to confirm your selected option (-3, -2, -1, 0, +1, +2, +3).
6. Press the **MENU** button twice to exit the settings menu.

2.5.6 Metering

Metering mode refers to the way in which a camera determines the appropriate exposure (quantity of light reaching the camera lens). Spot metering will only base the exposure setting on a very small area of the scene. Center metering will use the light from the center of the LCD and the Multi setting measures the light at several points on the screen.

1. In Video Mode press the **MENU** button.
2. Press the **OK** button to enter the Photo mode settings.
3. Select '*Metering*' using the **UP** or **DOWN** buttons.
4. Press the **OK** button to enter the Metering submenu.
5. Press the **UP** or **DOWN** buttons to navigate the menu, and press the **OK** button to confirm your selected option (*Multi, Center, Spot, Matrix*).
6. Press the **MENU** button twice to exit the settings menu.

2.5.7 Sharpness

This function adjusts the visible detail of a photograph.

1. In Video Mode press the **MENU** button.
2. Press the **OK** button to enter the Photo mode settings.
3. Select '*Sharpness*' using the **UP** or **DOWN** buttons.
4. Press the **OK** button to enter the Sharpness submenu.
5. Press the **UP** or **DOWN** buttons to navigate the menu, and press the **OK** button to confirm your selected option (*Sharp, Normal, Soft*).
6. Press the **MENU** button twice to exit the settings menu.

2.5.8 Video Quality

The Video Quality function determines the level of compression the camera uses when saving videos to a memory card.

1. In Video Mode press the **MENU** button.
2. Press the **OK** button to enter the Photo mode settings.
3. Select '*Video Quality*' using the **UP** or **DOWN** buttons.
4. Press the **OK** button to enter the Video Quality submenu.
5. Press the **UP** or **DOWN** buttons to navigate the menu, and press the **OK** button to confirm your selected option (*Normal, Fine, Super Fine*), Super Fine uses the least amount of compression for saving, and as a result produces a higher photo quality.
6. Press the **MENU** button twice to exit the settings menu.

2.5.9 ISO

This function adjusts the light sensitivity in your photograph.

1. In Video Mode press the **MENU** button.
2. Press the **OK** button to enter the Photo mode settings.
3. Select '*ISO*' using the **UP** or **DOWN** buttons.
4. Press the **OK** button to enter the ISO submenu.
5. Press the **UP** or **DOWN** buttons to navigate the menu, and press the **OK** button to confirm your selected option (*Auto, 100, 200, 400, 800, 1600, 3200, 6400*).
6. Press the **MENU** button twice to exit the settings menu.

2.5.10 Time Stamp

This setting allows you to imprint a date & time onto your captured image files. Once an image file is captured with the imprint, the imprint cannot be removed.

1. In Video Mode press the **MENU** button.
2. Press the **OK** button to enter the Photo mode settings.
3. Select '*Time Stamp*' using the **UP** or **DOWN** buttons.
4. Press the **OK** button to turn Time Stamp on and off, a check mark indicates that the feature is active.
5. Press the **MENU** button twice to exit the settings menu.

2.5.11 Record Audio

This setting allows you to select the built-in microphone ON or OFF during a video recording. Once you select an option, your camcorder will either record audio within the video file, or record a video file without the audio.

1. In Video Mode press the **MENU** button.
2. Press the **OK** button to enter the Photo mode settings.
3. Select '*Record Audio*' using the **UP** or **DOWN** buttons.
4. Press the **OK** button to turn Record Audio on and off, a check mark indicates that the feature is active.
5. Press the **MENU** button twice to exit the settings menu

2.5.12 Field of View

This function lets you set the field of view that the camera captures.

1. In Video Mode press the **MENU** button.
2. Press the **OK** button to enter the Photo mode settings.
3. Select '*Field of View*' using the **UP** or **DOWN** buttons.
4. Press the **OK** button to enter the Field of View submenu.
5. Press the **UP** or **DOWN** buttons to navigate the menu, and press the **OK** button to confirm your selected option (*Wide, Standard, Narrow*).
6. Press the **MENU** button twice to exit the settings menu.

2.6 Slow Motion Recording

Videos recorded in slow motion are recorded at a much higher frames per second and when played back, the videos show movement at a much slower rate.

To enter Slow Motion mode, power the camera on and press the **MODE** button to access the mode selection screen and use the **UP** or **DOWN** buttons to select '*Slow-mo*' and press the **OK** button to enter that mode.

1. Line up your shot by looking at the LCD screen to see what is in view.
2. Hold the camera steady and press the **SHUTTER** button to begin recording.
3. When recording begins, a rolling timer will display in red in the top left corner of the screen. This indicates the recorded video time elapsed.
4. Press the **SHUTTER** button to stop recording.
5. The recorded video files will automatically save onto the inserted memory card.

The front LCD screen can be used to take selfies. Simply press the **SWITCH SCREEN** button and the front LCD screen will turn on. Then use the camera as normal. Press the **SWITCH SCREEN** button to turn the rear LCD screen back on.

Note: Only one LCD screen is active at a time, when one of the screens is off, this is not a malfunction.

2.6.1 Slow Motion Rate

This function allows you to set the rate that the video is recorded in. If you choose 1080p 4X, your video will playback at $\frac{1}{4}$ speed and if you choose 1080p 2X, then your video will playback at $\frac{1}{2}$ speed.

Your camera has a number of preset resolutions and frames per second rates.

1. In Slow Motion Mode press the **MENU** button.
2. Press the **OK** button to enter the Photo mode settings.
3. Select '*Slow Motion Rate*' using the **UP** or **DOWN** buttons.
4. Press the **OK** button to enter the Movie Size submenu.
5. Press the **UP** or **DOWN** buttons to navigate the menu, and press the **OK**

button to confirm your selected resolution (*1080P 4X, 1080P 2X, 720P 8X, 720P 4X*).

6. Press the **MENU** button twice to exit the settings menu.

2.6.2 White Balance

White Balance changes the color of light in your pictures, making it seem warmer or cooler depending on how the light you're shooting in affects the frame.

1. In Slow Motion Mode press the **MENU** button.
2. Press the **OK** button to enter the Photo mode settings.
3. Select '*White Balance*' using the **UP** or **DOWN** buttons.
4. Press the **OK** button to enter the White Balance submenu.
5. Press the **UP** or **DOWN** buttons to navigate the menu, and press the **OK** button to confirm your selected option (*Auto, Sunny, Cloudy, Incandescent, Florescent*).
6. Press the **MENU** button twice to exit the settings menu.

2.6.3 Exposure

This function adjusts the frame brightness in your photograph.

1. In Slow Motion Mode press the **MENU** button.
2. Press the **OK** button to enter the Photo mode settings.
3. Select '*Exposure*' using the **UP** or **DOWN** buttons.
4. Press the **OK** button to enter the Exposure submenu.
5. Press the **UP** or **DOWN** buttons to navigate the menu, and press the **OK** button to confirm your selected option (*-3, -2, -1, 0, +1, +2, +3*).
6. Press the **MENU** button twice to exit the settings menu.

2.6.4 Metering

Metering mode refers to the way in which a camera determines the appropriate exposure (quantity of light reaching the camera lens). Spot metering will only base the exposure setting on a very small area of the scene. Center metering will use the light from the center of the LCD and the Multi setting measures the light at several points on the screen.

1. In Slow Motion Mode press the **MENU** button.
2. Press the **OK** button to enter the Photo mode settings.

3. Select '*Metering*' using the **UP** or **DOWN** buttons.
4. Press the **OK** button to enter the Metering submenu.
5. Press the **UP** or **DOWN** buttons to navigate the menu, and press the **OK** button to confirm your selected option (*Multi, Center, Spot, Matrix*).
6. Press the **MENU** button twice to exit the settings menu.

2.6.5 Sharpness

This function adjusts the visible detail of a photograph.

1. In Slow Motion Mode press the **MENU** button.
2. Press the **OK** button to enter the Photo mode settings.
3. Select '*Sharpness*' using the **UP** or **DOWN** buttons.
4. Press the **OK** button to enter the Sharpness submenu.
5. Press the **UP** or **DOWN** buttons to navigate the menu, and press the **OK** button to confirm your selected option (*Sharp, Normal, Soft*).
6. Press the **MENU** button twice to exit the settings menu.

2.6.6 Video Quality

The Video Quality function determines the level of compression the camera uses when saving videos to a memory card.

1. In Slow Motion Mode press the **MENU** button.
2. Press the **OK** button to enter the Photo mode settings.
3. Select '*Video Quality*' using the **UP** or **DOWN** buttons.
4. Press the **OK** button to enter the Video Quality submenu.
5. Press the **UP** or **DOWN** buttons to navigate the menu, and press the **OK** button to confirm your selected option (*Normal, Fine, Super Fine*), Super Fine uses the least amount of compression for saving, and as a result produces a higher photo quality.
6. Press the **MENU** button twice to exit the settings menu.

2.6.7 Field of View

This function lets you set the field of view that the camera captures.

1. In Slow Motion Mode press the **MENU** button.
2. Press the **OK** button to enter the Photo mode settings.
3. Select '*Field of View*' using the **UP** or **DOWN** buttons.
4. Press the **OK** button to enter the Field of View submenu.

5. Press the **UP** or **DOWN** buttons to navigate the menu, and press the **OK** button to confirm your selected option (*Wide, Standard, Narrow*).
6. Press the **MENU** button twice to exit the settings menu.

2.7 Loop Recording

This function allows you to set a maximum duration for each video clip recorded.

To enter Loop Recording mode, power the camera on and press the **MODE** button to access the mode selection screen and use the **UP** or **DOWN** buttons to select '*Loop*' and press the **OK** button to enter that mode.

1. Line up your shot by looking at the LCD screen to see what is in view.
2. Hold the camera steady and press the **SHUTTER** button to begin recording.
3. When recording begins, a rolling timer will display in red in the top left corner of the screen. This indicates the recorded video time elapsed.
4. After the set amount of time has elapsed, the recording will end and a new recording will start.
5. Press the **SHUTTER** button to stop recording.
6. The recorded video files will automatically save onto the inserted memory card.

The front LCD screen can be used to take selfies. Simply press the **SWITCH SCREEN** button and the front LCD screen will turn on. Then use the camera as normal. Press the **SWITCH SCREEN** button to turn the rear LCD screen back on.

Note: Only one LCD screen is active at a time, when one of the screens is off, this is not a malfunction.

2.7.1 Movie Size

Your camera has a number of preset resolutions and frames per second rates.

1. In Video Mode press the **MENU** button.
2. Press the **OK** button to enter the Photo mode settings.
3. Select '*Movie Size*' using the **UP** or **DOWN** buttons.
4. Press the **OK** button to enter the Movie Size submenu.
5. Press the **UP** or **DOWN** buttons to navigate the menu, and press the **OK** button to confirm your selected resolution (*4K (30fps)*, *2.7K (30fps)*, *1080P*

(120fps), 1080P (60fps), 1080P (30fps), 720P (240fps), 720P (120fps), 720P (60fps), 720P (30fps)).

6. Press the **MENU** button twice to exit the settings menu.

2.7.2 Loop Duration

This function allows you to set a maximum duration for each video clip recorded.

1. In Video Mode press the **MENU** button.
2. Press the **OK** button to enter the Photo mode settings.
3. Select '*Loop Duration*' using the **UP** or **DOWN** buttons.
4. Press the **OK** button to enter the Loop Duration submenu.
5. Press the **UP** or **DOWN** buttons to navigate the menu, and press the **OK** button to confirm your selected resolution (*2 Minutes, 3 Minutes, 5 Minutes*).
6. Press the **MENU** button twice to exit the settings menu.

2.7.3 Image Stabilization

This function enables photo capture in high speed and low-light by electronically minimizing motion blur and reducing camera shake.

1. In Video Mode press the **MENU** button.
2. Press the **OK** button to enter the Photo mode settings.
3. Select '*Image Stabilization*' using the **UP** or **DOWN** buttons.
4. Press the **OK** button to turn Image Stabilization on and off, a check mark indicates that the feature is active.
5. Press the **MENU** button twice to exit the settings menu.

Note: Image Stabilization and Distortion correction cannot be active at the same time.

2.7.4 Distortion Correction

This function enables the camera to correct slight image distortion by straightening the image and enhances it to appear more natural.

1. In Video Mode press the **MENU** button.
2. Press the **OK** button to enter the Photo mode settings.
3. Select '*Distortion Correction*' using the **UP** or **DOWN** buttons.
4. Press the **OK** button to turn Distortion Correction on and off, a check mark

indicates that the feature is active.

5. Press the **MENU** button twice to exit the settings menu.

2.7.5 White Balance

White Balance changes the color of light in your pictures, making it seem warmer or cooler depending on how the light you're shooting in affects the frame.

1. In Video Mode press the **MENU** button.
2. Press the **OK** button to enter the Photo mode settings.
3. Select '*White Balance*' using the **UP** or **DOWN** buttons.
4. Press the **OK** button to enter the White Balance submenu.
5. Press the **UP** or **DOWN** buttons to navigate the menu, and press the **OK** button to confirm your selected option (*Auto, Sunny, Cloudy, Incandescent, Florescent*).
6. Press the **MENU** button twice to exit the settings menu.

2.7.6 Exposure

This function adjusts the frame brightness in your photograph.

1. In Video Mode press the **MENU** button.
2. Press the **OK** button to enter the Photo mode settings.
3. Select '*Exposure*' using the **UP** or **DOWN** buttons.
4. Press the **OK** button to enter the Exposure submenu.
5. Press the **UP** or **DOWN** buttons to navigate the menu, and press the **OK** button to confirm your selected option (*-3, -2, -1, 0, +1, +2, +3*).
6. Press the **MENU** button twice to exit the settings menu.

2.7.7 Metering

Metering mode refers to the way in which a camera determines the appropriate exposure (quantity of light reaching the camera lens). Spot metering will only base the exposure setting on a very small area of the scene. Center metering will use the light from the center of the LCD and the Multi setting measures the light at several points on the screen.

1. In Video Mode press the **MENU** button.
2. Press the **OK** button to enter the Photo mode settings.
3. Select '*Metering*' using the **UP** or **DOWN** buttons.

4. Press the **OK** button to enter the Metering submenu.
5. Press the **UP** or **DOWN** buttons to navigate the menu, and press the **OK** button to confirm your selected option (*Multi, Center, Spot, Matrix*).
6. Press the **MENU** button twice to exit the settings menu.

2.7.8 Sharpness

This function adjusts the visible detail of a photograph.

1. In Video Mode press the **MENU** button.
2. Press the **OK** button to enter the Photo mode settings.
3. Select '*Sharpness*' using the **UP** or **DOWN** buttons.
4. Press the **OK** button to enter the Sharpness submenu.
5. Press the **UP** or **DOWN** buttons to navigate the menu, and press the **OK** button to confirm your selected option (*Sharp, Normal, Soft*).
6. Press the **MENU** button twice to exit the settings menu.

2.7.9 Video Quality

The Video Quality function determines the level of compression the camera uses when saving videos to a memory card.

1. In Video Mode press the **MENU** button.
2. Press the **OK** button to enter the Photo mode settings.
3. Select '*Video Quality*' using the **UP** or **DOWN** buttons.
4. Press the **OK** button to enter the Video Quality submenu.
5. Press the **UP** or **DOWN** buttons to navigate the menu, and press the **OK** button to confirm your selected option (*Normal, Fine, Super Fine*), Super Fine uses the least amount of compression for saving, and as a result produces a higher photo quality.
6. Press the **MENU** button twice to exit the settings menu.

2.7.10 ISO

This function adjusts the light sensitivity in your photograph.

1. In Video Mode press the **MENU** button.
2. Press the **OK** button to enter the Photo mode settings.
3. Select '*ISO*' using the **UP** or **DOWN** buttons.
4. Press the **OK** button to enter the ISO submenu.
5. Press the **UP** or **DOWN** buttons to navigate the menu, and press the **OK**

button to confirm your selected option (*Auto, 100, 200, 400, 800, 1600, 3200, 6400*).

6. Press the **MENU** button twice to exit the settings menu.

2.7.11 Time Stamp

This setting allows you to imprint a date & time onto your captured image files. Once an image file is captured with the imprint, the imprint cannot be removed.

1. In Video Mode press the **MENU** button.
2. Press the **OK** button to enter the Photo mode settings.
3. Select '*Time Stamp*' using the **UP** or **DOWN** buttons.
4. Press the **OK** button to turn Time Stamp on and off, a check mark indicates that the feature is active.
5. Press the **MENU** button twice to exit the settings menu.

2.7.12 Record Audio

This setting allows you to select the built-in microphone ON or OFF during a video recording. Once you select an option, your camcorder will either record audio within the video file, or record a video file without the audio.

1. In Video Mode press the **MENU** button.
2. Press the **OK** button to enter the Photo mode settings.
3. Select '*Record Audio*' using the **UP** or **DOWN** buttons.
4. Press the **OK** button to turn Record Audio on and off, a check mark indicates that the feature is active.
5. Press the **MENU** button twice to exit the settings menu

2.7.13 Field of View

This function lets you set the field of view that the camera captures.

1. In Video Mode press the **MENU** button.
2. Press the **OK** button to enter the Photo mode settings.
3. Select '*Field of View*' using the **UP** or **DOWN** buttons.
4. Press the **OK** button to enter the Field of View submenu.
5. Press the **UP** or **DOWN** buttons to navigate the menu, and press the **OK** button to confirm your selected option (*Wide, Standard, Narrow*).
6. Press the **MENU** button twice to exit the settings menu.

2.8 Time Lapse

This feature allows you to capture long sequences of events in a much shorter time period.

To enter Time Lapse mode, power the camera on and press the **MODE** button to access the mode selection screen and use the **UP** or **DOWN** buttons to select '*Lapse*' and press the **OK** button to enter that mode.

1. Line up your shot by looking at the LCD screen to see what is in view.
2. Hold the camera steady and press the **SHUTTER** button to begin recording.
3. When recording begins, a rolling timer will display in red in the top left corner of the screen. This indicates the recorded video time elapsed.
4. Press the **SHUTTER** button to stop recording.
5. The recorded video files will automatically save onto the inserted memory card.

The front LCD screen can be used to take selfies. Simply press the **SWITCH SCREEN** button and the front LCD screen will turn on. Then use the camera as normal. Press the **SWITCH SCREEN** button to turn the rear LCD screen back on.

Note: Only one LCD screen is active at a time, when one of the screens is off, this is not a malfunction.

2.8.1 Movie Size

Your camera has a number of preset resolutions and frames per second rates.

1. In Time Lapse Mode press the **MENU** button.
2. Press the **OK** button to enter the Photo mode settings.
3. Select '*Movie Size*' using the **UP** or **DOWN** buttons.
4. Press the **OK** button to enter the Movie Size submenu.
5. Press the **UP** or **DOWN** buttons to navigate the menu, and press the **OK** button to confirm your selected resolution (*4K, 2.7K, 1080P, 720P*).
6. Press the **MENU** button twice to exit the settings menu.

2.8.2 Interval Duration

This function allows you to set the amount of time in between images.

1. In Time Lapse Mode press the **MENU** button.
2. Press the **OK** button to enter the Photo mode settings.
3. Select '*Interval Duration*' using the **UP** or **DOWN** buttons.
4. Press the **OK** button to enter the Interval Duration submenu.
5. Press the **UP** or **DOWN** buttons to navigate the menu, and press the **OK** button to confirm your selected resolution (*0.5 Seconds, 1 Second, 2 Seconds, 5 Seconds, 10 Seconds, 30 Seconds, 60 Seconds*).
6. Press the **MENU** button twice to exit the settings menu.

NOTE: By selecting '10 Seconds' the camera will capture a single frame every 10 seconds and create a video combining all of the captured images. See the table below for how long it will take to record 1 second of video for each option;

Interval Duration Option	Length of time to record 1 second of video
0.5 Seconds	15 Seconds
1 Second	30 Seconds
2 Seconds	60 Seconds
5 Seconds	150 Seconds
10 Seconds	300 Seconds
30 Seconds	900 Seconds
60 Seconds	1,800 Seconds

2.8.3 Distortion Correction

This function enables the camera to correct slight image distortions by straightening the image and enhances it to appear more natural.

1. In Time Lapse Mode press the **MENU** button.
2. Press the **OK** button to enter the Photo mode settings.
3. Select '*Distortion Correction*' using the **UP** or **DOWN** buttons.
4. Press the **OK** button to turn Distortion Correction on and off, a check mark indicates that the feature is active.
5. Press the **MENU** button twice to exit the settings menu.

Note: Distortion Correction is only available when the Movie Size setting is 1080P or 720P.

2.8.4 White Balance

White Balance changes the color of light in your pictures, making it seem warmer or cooler depending on how the light you're shooting in affects the frame.

1. In Time Lapse Mode press the **MENU** button.
2. Press the **OK** button to enter the Photo mode settings.
3. Select '*White Balance*' using the **UP** or **DOWN** buttons.
4. Press the **OK** button to enter the White Balance submenu.
5. Press the **UP** or **DOWN** buttons to navigate the menu, and press the **OK** button to confirm your selected option (*Auto, Sunny, Cloudy, Incandescent, Florescent*).
6. Press the **MENU** button twice to exit the settings menu.

2.8.5 Exposure

This function adjusts the frame brightness in your photograph.

1. In Time Lapse Mode press the **MENU** button.
2. Press the **OK** button to enter the Photo mode settings.
3. Select '*Exposure*' using the **UP** or **DOWN** buttons.
4. Press the **OK** button to enter the Exposure submenu.
5. Press the **UP** or **DOWN** buttons to navigate the menu, and press the **OK** button to confirm your selected option (*-3, -2, -1, 0, +1, +2, +3*).
6. Press the **MENU** button twice to exit the settings menu.

2.8.6 Video Duration

This function allows you to set the length of the final time lapse video.

1. In Time Lapse Mode press the **MENU** button.
2. Press the **OK** button to enter the Photo mode settings.
3. Select '*Video Duration*' using the **UP** or **DOWN** buttons.
4. Press the **OK** button to enter the Video Duration submenu.
5. Press the **UP** or **DOWN** buttons to navigate the menu, and press the **OK** button to confirm your selected resolution (*Unlimited, 6 Seconds, 8 Seconds, 10 Seconds, 20 Seconds, 30 Seconds, 60 Seconds, 120 Seconds*).
6. Press the **MENU** button twice to exit the settings menu

NOTE: By selecting '10 Seconds' the time lapse will automatically stop recording when the final video is 10 seconds long. The actual length of time that it will take to record the 10 second video will depend on the interval duration, see section 2.8.2.

2.8.7 Metering

Metering mode refers to the way in which a camera determines the appropriate exposure (quantity of light reaching the camera lens). Spot metering will only base the exposure setting on a very small area of the scene. Center metering will use the light from the center of the LCD and the Multi setting measures the light at several points on the screen.

1. In Time Lapse Mode press the **MENU** button.
2. Press the **OK** button to enter the Photo mode settings.
3. Select 'Metering' using the **UP** or **DOWN** buttons.
4. Press the **OK** button to enter the Metering submenu.
5. Press the **UP** or **DOWN** buttons to navigate the menu, and press the **OK** button to confirm your selected option (*Multi, Center, Spot, Matrix*).
6. Press the **MENU** button twice to exit the settings menu.

2.8.8 Sharpness

This function adjusts the visible detail of a photograph.

1. In Time Lapse Mode press the **MENU** button.
2. Press the **OK** button to enter the Photo mode settings.
3. Select 'Sharpness' using the **UP** or **DOWN** buttons.
4. Press the **OK** button to enter the Sharpness submenu.
5. Press the **UP** or **DOWN** buttons to navigate the menu, and press the **OK** button to confirm your selected option (*Sharp, Normal, Soft*).
6. Press the **MENU** button twice to exit the settings menu.

2.8.9 Video Quality

The Video Quality function determines the level of compression the camera uses when saving videos to a memory card.

1. In Time Lapse Mode press the **MENU** button.
2. Press the **OK** button to enter the Photo mode settings.
3. Select 'Video Quality' using the **UP** or **DOWN** buttons.

4. Press the **OK** button to enter the Video Quality submenu.
5. Press the **UP** or **DOWN** buttons to navigate the menu, and press the **OK** button to confirm your selected option (*Normal, Fine, Super Fine*), Super Fine uses the least amount of compression for saving, and as a result produces a higher photo quality.
6. Press the **MENU** button twice to exit the settings menu.

2.8.10 ISO

This function adjusts the light sensitivity in your photograph.

1. In Time Lapse Mode press the **MENU** button.
2. Press the **OK** button to enter the Photo mode settings.
3. Select '*ISO*' using the **UP** or **DOWN** buttons.
4. Press the **OK** button to enter the ISO submenu.
5. Press the **UP** or **DOWN** buttons to navigate the menu, and press the **OK** button to confirm your selected option (*Auto, 100, 200, 400, 800, 1600, 3200, 6400*).
6. Press the **MENU** button twice to exit the settings menu.

2.9 Camera Settings

Basic settings can be changed in the Settings menu. These include date & time, language and sound options. Power the camera on and press the **MENU** button. Press the **DOWN** button so the gear icon is highlighted and press the **OK** button to enter the camera settings menu. A menu will display on the screen.

2.9.1 Image Rotation

This function allows you to flip the image on the LCD screens 180 degrees.

1. In All Photo and Video Modes press the **MENU** button.
2. Press the **DOWN** button so the gear icon is highlighted and press the **OK** button to enter the camera settings.
3. Select '*Image Rotation*' using the **UP** or **DOWN** buttons.
4. Press the **OK** button to turn Image Rotation on and off, a check mark indicates that the feature is active.
5. Press the **MENU** button twice to exit the settings menu.

2.9.2 Wi-Fi

This function allows you activate the Wi-Fi on the camera.

1. In All Photo and Video Modes press the **MENU** button.
2. Press the **DOWN** button so the gear icon is highlighted and press the **OK** button to enter the camera settings.
3. Select '*Wi-Fi*' using the **UP** or **DOWN** buttons.
4. Press the **OK** button to turn Wi-Fi on and off, a check mark indicates that the feature is active.
5. After turning on the Wi-Fi, the Wi-Fi network and password will be displayed on the screen. Press the **OK** button to turn the Wi-Fi off.
6. Press the **MENU** button twice to exit the settings menu.

2.9.3 Wi-Fi Information

This function displays the camera's Wi-Fi information.

1. In All Photo and Video Modes press the **MENU** button.
2. Press the **DOWN** button so the gear icon is highlighted and press the **OK** button to enter the camera settings.
3. Select '*Wi-Fi Information*' using the **UP** or **DOWN** buttons.
4. Press the **OK** button to enter the Wi-Fi Information submenu.

5. The Wi-Fi information will then be displayed on the screen. Press the OK button to exit the Wi-Fi information screen.
6. Press the **MENU** button twice to exit the settings menu.

2.9.4 Reset Wi-Fi

This function allows you to reset the Wi-Fi network on the camera.

1. In All Photo and Video Modes press the **MENU** button.
2. Press the **DOWN** button so the gear icon is highlighted and press the **OK** button to enter the camera settings.
3. Select '*Reset Wi-Fi*' using the **UP** or **DOWN** buttons.
4. Press the **OK** button to enter the Reset Wi-Fi submenu.
5. Press the UP or DOWN buttons to navigate the menu, and press the OK button to confirm your selected option (*Confirm, Cancel*).
6. Press the **MENU** button twice to exit the settings menu.

2.9.5 Frequency

This function sets the frequency of the camera from 50Hz to 60Hz. Please check the frequency of your location and set accordingly.

1. In All Photo and Video Modes press the **MENU** button.
2. Press the **DOWN** button so the gear icon is highlighted and press the **OK** button to enter the camera settings.
3. Select '*Frequency*' using the **UP** or **DOWN** buttons.
4. Press the **OK** button to enter the Frequency submenu
5. Press the **UP** or **DOWN** buttons to navigate the menu, and press the OK button to confirm your selected option (*Auto, 50 Hz, 60 Hz*) the default frequency for the United States is 60Hz.
6. Press the **MODE** button to exit the settings menu.

2.9.6 LED Indicator

This function allows you turn the LED status indicator on and off.

1. In All Photo and Video Modes press the **MENU** button.
2. Press the **DOWN** button so the gear icon is highlighted and press the **OK** button to enter the camera settings.
3. Select '*LED Indicator*' using the **UP** or **DOWN** buttons.
4. Press the **OK** button to turn the LED Indicator on and off, a check mark

indicates that the feature is active.

5. Press the **MENU** button twice to exit the settings menu.

2.9.7 Screen Saver

This function sets the duration of time in which the camcorder will wait with no user input before automatically turning off the LCD screen. Note: even while the screen is off, the camera will still be powered on.

1. In All Photo and Video Modes press the **MENU** button.
2. Press the **DOWN** button so the gear icon is highlighted and press the **OK** button to enter the camera settings.
3. Select 'Screen Saver' using the **UP** or **DOWN** buttons.
4. Press the **OK** button to enter the Screen Saver submenu.
5. Press the **UP** or **DOWN** buttons to navigate the menu, and press the **OK** button to confirm your selected option (*Off, 30 Seconds, 1 Minute, 2 Minutes*).
6. Press the **MENU** button twice to exit the settings menu.

2.9.8 Auto Power Off

This function sets the duration of time in which the camera will wait with no user input before automatically powering off.

1. In All Photo and Video Modes press the **MENU** button.
2. Press the **DOWN** button so the gear icon is highlighted and press the **OK** button to enter the camera settings.
3. Select 'Auto Power Off' using the **UP** or **DOWN** buttons.
4. Press the **OK** button to enter the Auto Power Off submenu.
5. Press the **UP** or **DOWN** buttons to navigate the menu, and press the **OK** button to confirm your selected option (*Off, 3 Minutes, 5 Minutes, 10 Minutes*).
6. Press the **MENU** button twice to exit the settings menu.

2.9.9 Button Sound

This function allows you to turn off the sounds of the camera.

1. In All Photo and Video Modes press the **MENU** button.
2. Press the **DOWN** button so the gear icon is highlighted and press the **OK** button to enter the camera settings.

3. Select '*Button Sound*' using the **UP** or **DOWN** buttons.
4. Press the **OK** button to enter the Button Sound submenu.
5. Press the **UP** or **DOWN** buttons to navigate the menu, and press the **OK** button to confirm your selected option (*High, Medium, Low, Off*).
6. Press the **MENU** button twice to exit the settings menu.

2.9.10 Language

This function allows you to set the camera's interface language.

1. In All Photo and Video Modes press the **MENU** button.
2. Press the **DOWN** button so the gear icon is highlighted and press the **OK** button to enter the camera settings.
3. Select '*Language*' using the **UP** or **DOWN** buttons.
4. Press the **OK** button to enter the Language submenu.
5. Press the **UP** or **DOWN** buttons to navigate the menu, and press the **OK** button to confirm your selected language.
6. Press the **MENU** button twice to exit the settings menu.

2.9.11 Date Format

This function allows you to set the date format on the camera.

1. In All Photo and Video Modes press the **MENU** button.
2. Press the **DOWN** button so the gear icon is highlighted and press the **OK** button to enter the camera settings.
3. Select '*Date Format*' using the **UP** or **DOWN** buttons.
4. Press the **OK** button to enter the Date Format submenu.
5. Press the **UP** or **DOWN** buttons to navigate the menu, and press the **OK** button to confirm your selected option (*YYYY/MM/DD, MM/DD/YYYY, DD-MM-YYYY*).
6. Press the **MENU** button twice to exit the settings menu.

2.9.12 Time Set

This function allows you to set the current time on the camera.

1. In All Photo and Video Modes press the **MENU** button.
2. Press the **DOWN** button so the gear icon is highlighted and press the **OK** button to enter the camera settings.
3. Select '*Time Set*' using the **UP** or **DOWN** buttons.

4. Press the **OK** button to enter the Time Set submenu.
5. Press the **UP** or **DOWN** buttons to change the highlighted value and press the **OK** button to switch the highlighted value.
6. Press the **MENU** button to save the settings and exit the submenu.
7. Press the **MENU** button twice to exit the settings menu.

2.9.13 Date Set

This function allows you to set the current date on the camera.

1. In All Photo and Video Modes press the **MENU** button.
2. Press the **DOWN** button so the gear icon is highlighted and press the **OK** button to enter the camera settings.
3. Select '*Date Set*' using the **UP** or **DOWN** buttons.
4. Press the **OK** button to enter the Date Set submenu.
5. Press the **UP** or **DOWN** buttons to change the highlighted value and press the **OK** button to switch the highlighted value.
6. Press the **MENU** button to save the settings and exit the submenu.
7. Press the **MENU** button twice to exit the settings menu.

2.9.14 Format Memory Card

The format setting erases all photos, videos and data stored on your memory card.

1. In All Photo and Video Modes press the **MENU** button.
2. Press the **DOWN** button so the gear icon is highlighted and press the **OK** button to enter the camera settings.
3. Select '*Format Memory Card*' using the **UP** or **DOWN** buttons.
4. Press the **OK** button to enter the Format Memory Card submenu.
5. Press the **UP** or **DOWN** buttons to navigate the menu, and press the **OK** button to confirm your selected option (*Format, Cancel*).
6. Press the **MENU** button twice to exit the settings menu.

NOTE: This will delete all of your media and cannot be undone.

2.9.15 Device Info

This setting displays the current firmware version of your camera.

1. In All Photo and Video Modes press the **MENU** button.
2. Press the **DOWN** button so the gear icon is highlighted and press the **OK**

button to enter the camera settings.

3. Select '*Device Info*' using the **UP** or **DOWN** buttons.
4. Press the **OK** button to enter the Device Info submenu.
5. The device info will then be displayed on the screen, press the **OK** button to exit the Device Info screen.
6. Press the **MENU** button twice to exit the settings menu.

2.9.16 Restore Default Settings

Factory default settings can be restored in this menu. This function will not delete the media stored on the memory card, and will only restore all of the menu's setting back to factory default settings.

1. In All Photo and Video Modes press the **MENU** button.
2. Press the **DOWN** button so the gear icon is highlighted and press the **OK** button to enter the camera settings.
3. Select '*Restore Default Settings*' using the **UP** or **DOWN** buttons.
4. Press the **OK** button to enter the Restore Default Settings submenu.
5. Press the **UP** or **DOWN** buttons to navigate the menu, and press the **OK** button to confirm your selected option (*Confirm, Cancel*).
6. Press the **MENU** button twice to exit the settings menu.

2.10 Playback Mode

Videos and photos captured on your camera can be easily played back.

1. Press the **MODE** button to enter Playback mode.
2. Press the **UP** or **DOWN** buttons to cycle through the captured videos and photos stored on the memory card.
3. While viewing a recorded video, press the **OK** button to start the video, and press the **OK** button again to pause the video.
4. Press and hold the **OK** button to access the delete submenu.
5. Press the **UP** or **DOWN** buttons to navigate the menu and press the **OK** button to confirm your selected option (*Delete, Cancel*).

2.11 Wireless Connectivity

2.11.1 Connecting to the DV King 4K App

To wirelessly operate the MN60WP camera you will need to install the “DV King 4K” app on your Android or iOS device. To download the app, search for “DV King 4K” in the Apple App Store or Google Play Store.

The camera can be operated remotely by following the steps below:

1. Turn the camera on and press the **MENU** button.
2. Press the **DOWN** button so the gear icon is highlighted and press the **OK** button to enter the camera settings. Then press the **UP** or **DOWN** buttons to select Wi-Fi and press the **OK** button to activate Wi-Fi mode. The Network Name (SSID) and the password will be displayed on the screen.
3. To close the wireless menu, press the **OK** button.
4. Open your phone’s wireless menu, turn all wireless settings on and connect to the network named “MN60WP-XXXX” then join the network, password is 1234567890.
5. Exit the wireless menu on your smartphone and open the “DV King 4K” app to launch remote operation of the camcorder.
6. The connected camera will show on the top of the screen.
7. Select the camera by tapping the camera name.



2.11.2 Operating the DV King 4K App

Your MN60WP will now be operable via your smartphone. It will initially default to the video recording function. To change to Photo Mode, press the camera icon in the bottom of your phone screen.

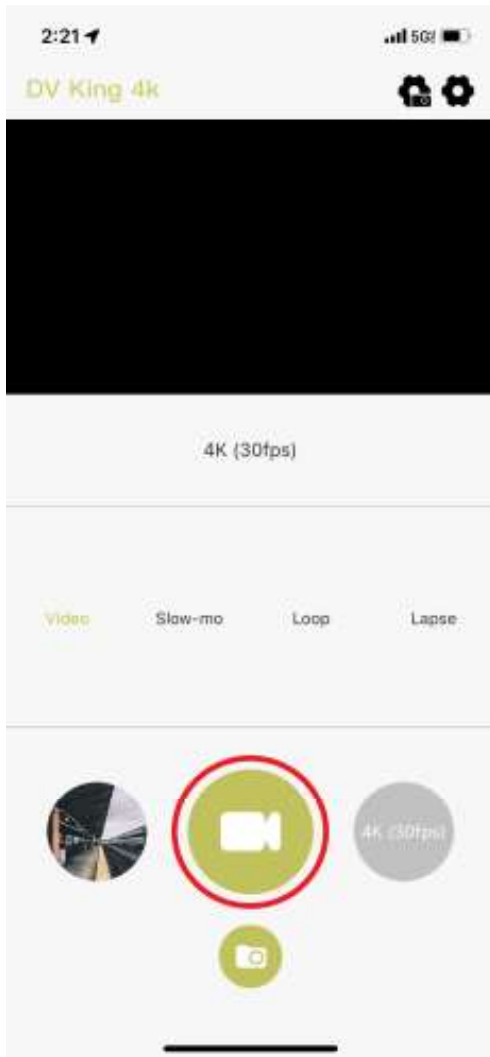

Video Mode

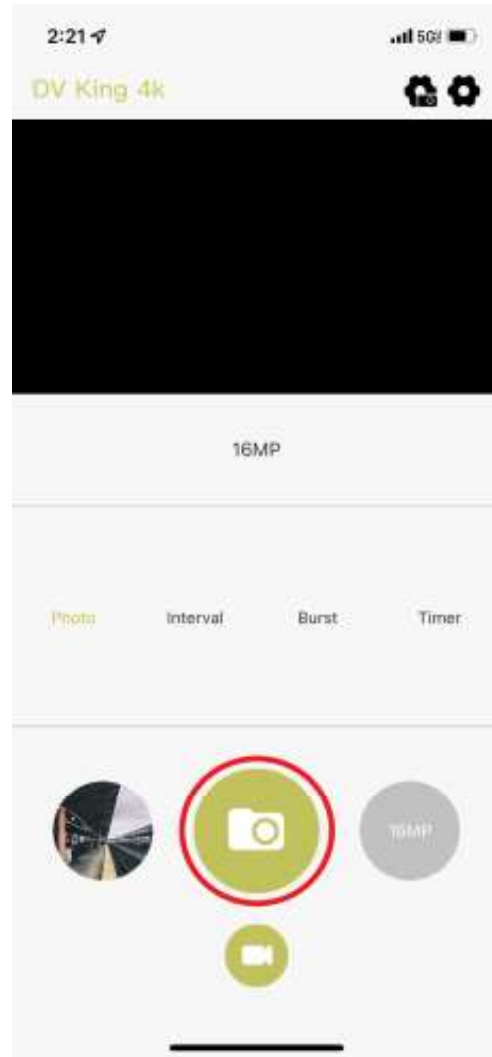
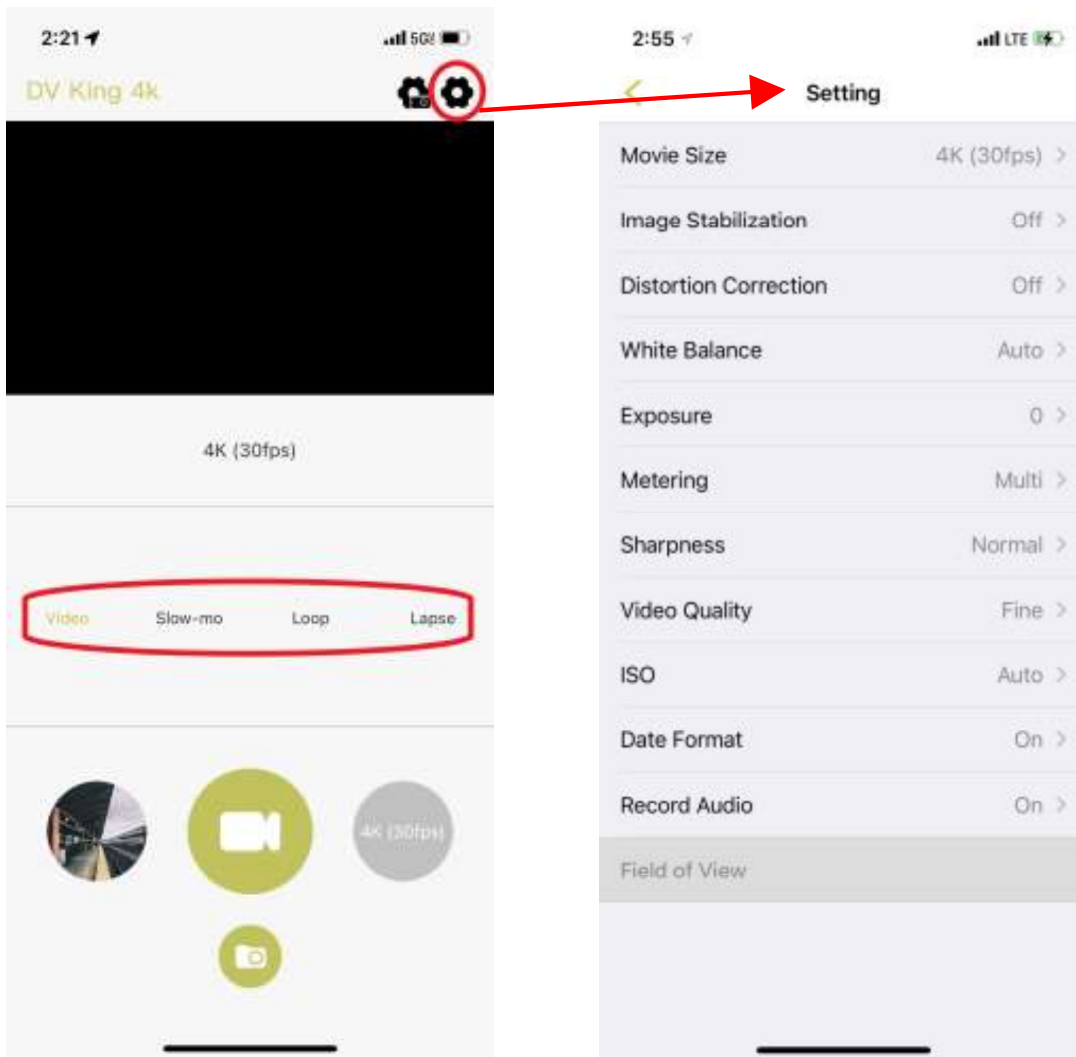

Photo Mode

2.11.3 Recording Videos Remotely

1. To start recording a video, press the record button, a video camera icon, in the middle of your smartphone's screen.
2. The video recording mode can be changed by selecting the mode name from the middle of your smartphone's screen.
3. The video mode settings can be accessed by selecting the gear icon in the top right corner of your smartphone's screen.



2.11.4 Taking Photos Remotely

1. To capture a photo, press the capture button, a camera icon, in the middle of your smartphone's screen.
2. The photo capture mode can be changed by selecting the mode name from the middle of your smartphone's screen.
3. The photo mode settings can be accessed by selecting the gear icon in the top right corner of your smartphone's screen.

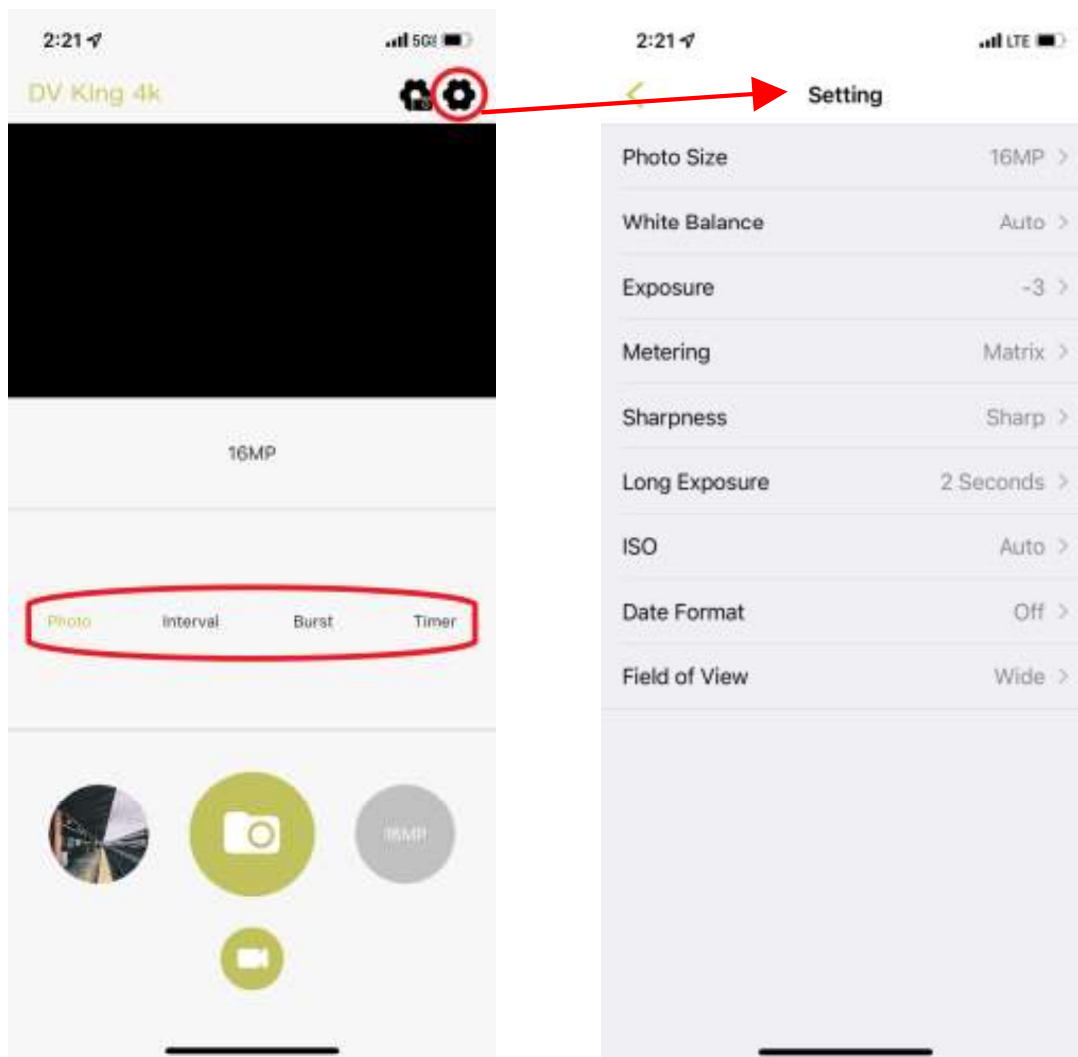

2.11.5 Viewing Media on the App

1. To view the recorded images and videos stored on the memory card on the app, press the photo gallery button in the bottom left of your smartphone's screen.
2. Tap the photo or video file you wish to view. From this screen media can be saved to your smartphone and deleted. If a photo or video is deleted on the app, it will also be removed from the memory card in the camera.

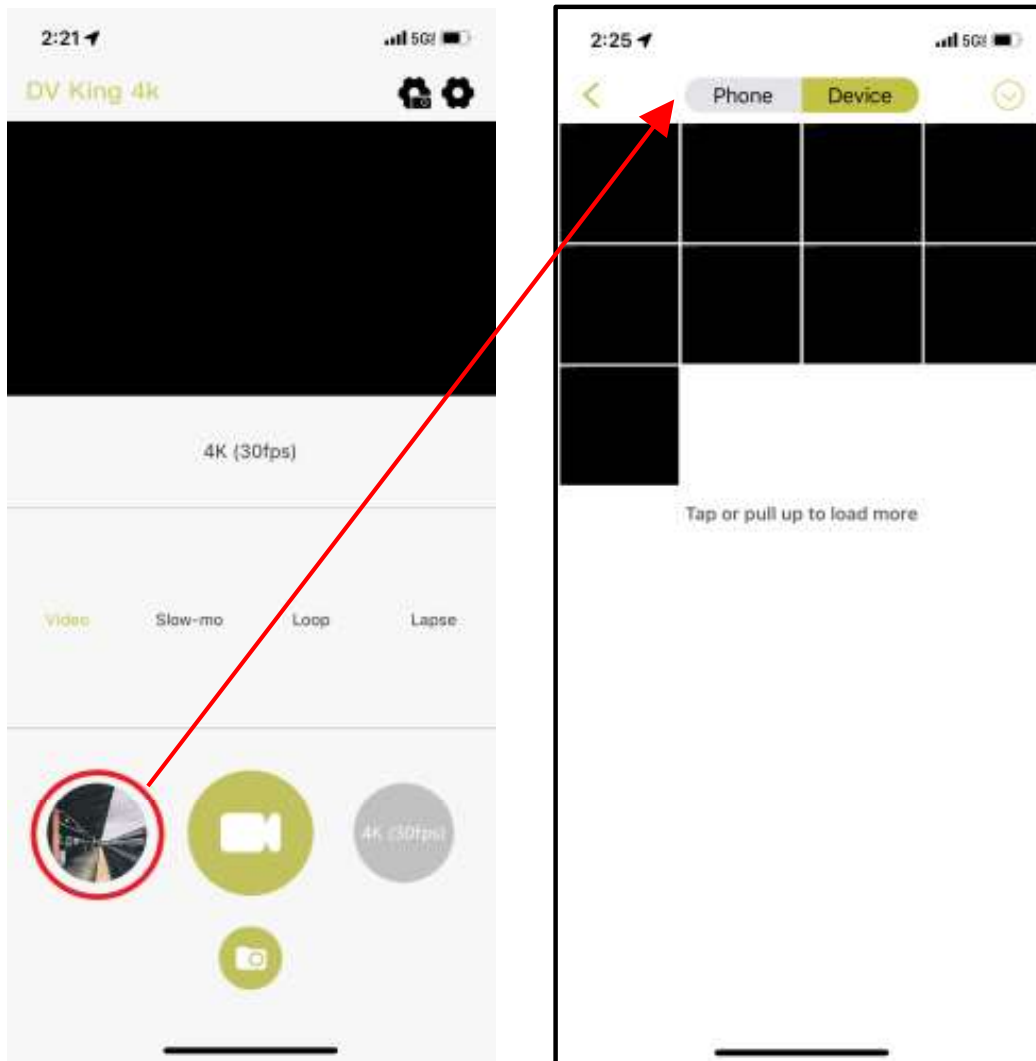

2.11.6 Changing Camera Settings on the App

Camcorder settings can also be changed on the app. Press the icon in the top right corner of your smartphone's screen to launch the settings menu. From here, a number of settings including can be changed.

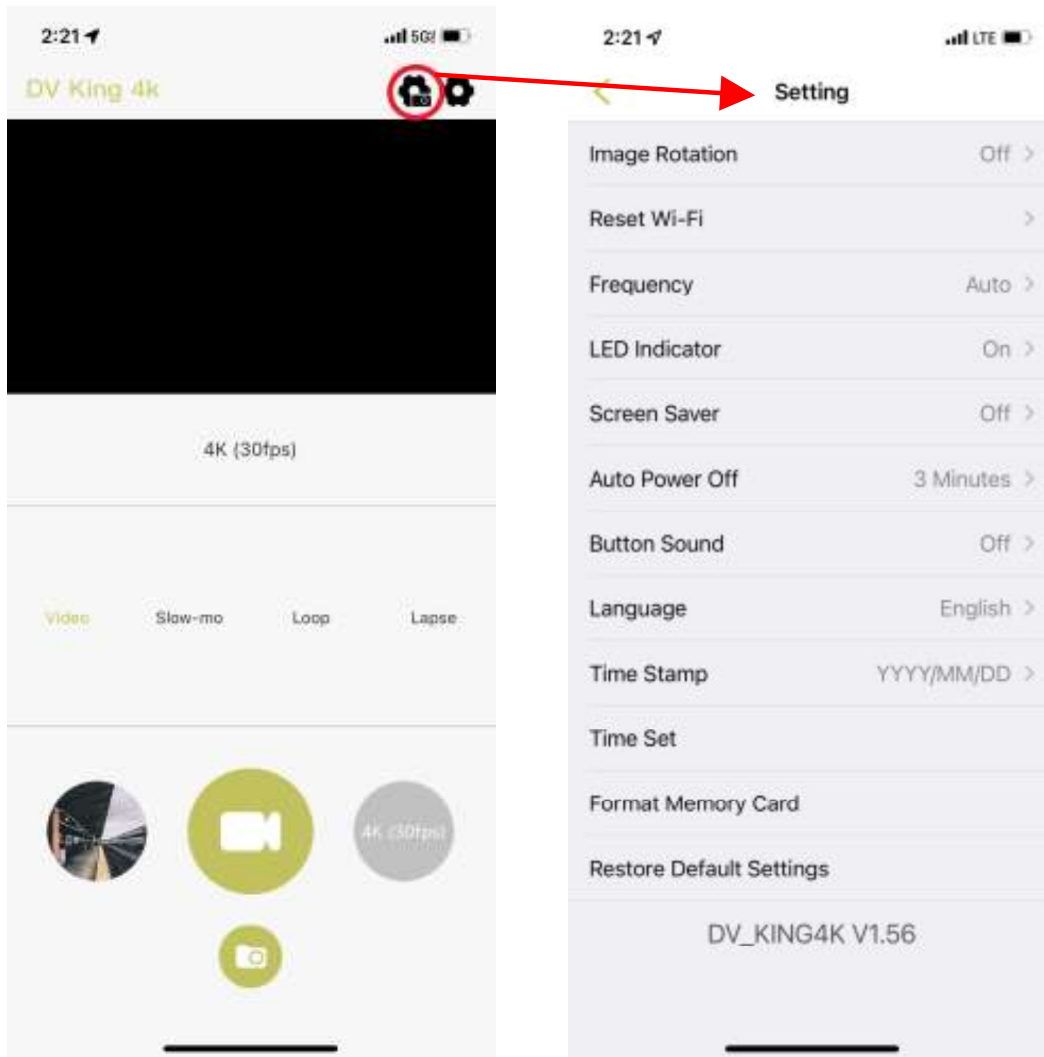

4.1 Technical Specifications

Model Number	Minolta MN60WP
Lens	Fixed Focus • f=4.0mm • F/2.2
Zoom	16X Digital Zoom
Image Sensor	12MP CMOS Sensor
Shutter	Electronic • Anti-Shake Image Stabilization
Pixels (photo)	JPEG: 48MP • 30MP • 24MP • 20MP • 16MP • 13MP • 12MP • 8MP
Pixels (video)	MP4: 4K (30fps) • 2.7K (30fps) • 1080P (120fps) • 1080P (60fps) • 1080P (30fps) • 720P (240fps) • 720P (120fps) • 720P (60fps) • 720P (30fps)
Wireless Connection	P2P with iOS or Android • App Name: “DV King 4K”
ISO Sensitivity	Auto • 100 • 200 • 400 • 800 • 1600 • 3200 • 6400
LCD Screen	Rear: 2.7” IPS LCD Screen
	Front: 1.8” IPS LCD Screen
Assistive Light	White LED
Waterproof	IP68 Rating • Up to 16 feet
Power Saving	OFF • 3 Minutes • 5 Minutes • 10 Minutes
White Balance Control	Auto • Sunny • Cloudy • Incandescent • Florescent
Special Features	Slow-Motion Recording • Loop Recording • Photo Burst • Time Lapse • PC Camera Mode
Color Effects	Normal • Black and White • Negative • Retro • Red • Green • Blue
Recording Media	Micro SD • MicroSDHC; Maximum: 128GB
I/O Ports	5-pin Micro USB, USB 2.0 (high speed) • Microphone (built-in MIC) • Speaker
Power	Lithium-Ion 3.7V, 1,050mAh
Dimensions	4.25 x 2.67 x 1.38 in. • 5.2 oz.



MINOLTA®

*Minolta is a registered trademark of JMM Lee Properties, LLC
and is used in the United States by Elite Brands Inc. under license.*

*40 Wall Street, 61st Floor, New York, NY 10005 USA • Tel: 800-441-1100
www.minoltadigital.com • www.elitebrands.com
Copyright © 2023 Elite Brands Inc.*

***If you're having difficulties with your camera, or would like further assistance,
please call our toll-free technical support hotline at 800-441-1100. Please be
sure to have your camera handy when calling.***





MINOLTA®

MN60WP

